



# PBM-UNI Heavy Duty Universal Projector Mount

**ITEM:** PBM-UNI

**WEIGHT CAPACITY:**  
150 LB/ 68 KG

## FEATURES

- 1 Can be secured to a single wood stud, standard 1.5 in NPT pipe, or directly to the ceiling
- 2 Slotted mounting base with adjustable legs reach wider mounting points
- 3 Can be attached to optional adjustable suspension adapters for a faster and easier installation
- 4 Cable routing through NPT pipe or adjustable suspension adapters

The PBM-UNI is a Heavy Duty Universal Projector Mount for projectors weighing up to 150 lb/68 kg. It can be secured to a single wood stud, standard 1.5 in NPT pipe, or directly to the ceiling. It can be attached to optional adjustable suspension adapters for a faster and easier installation. The slotted base with adjustable legs reach wider mounting points. There are 15° of rotation adjustments if secured to the ceiling, or 360° of rotation when used with NPT pipe, +/- 6° tilt and +/- 3° roll with positive locking of set angles.

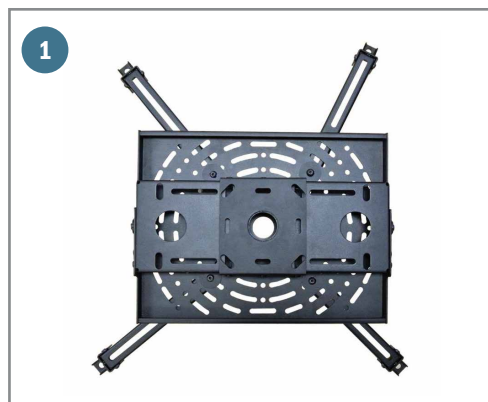
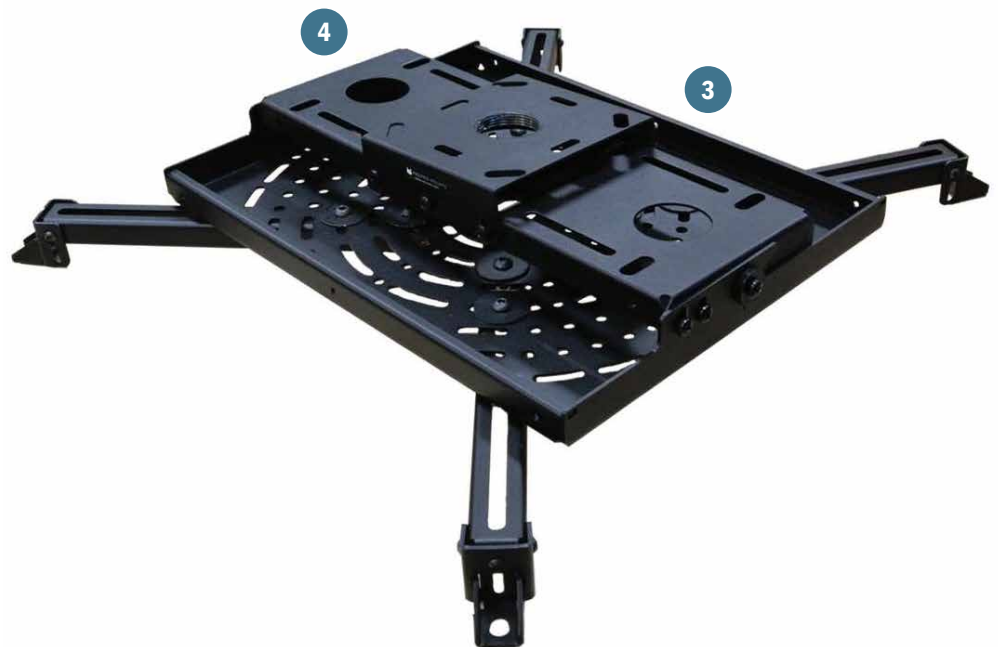



# PBM-UNI Heavy Duty Universal Projector Mount

## SPECIFICATIONS

WEIGHT	COLOR	WEIGHT CAPACITY/MOUNT		
19.68 lb.   8.9 kg	Black	150 lb.   68 kg		
WIDTH x HEIGHT x DEPTH	PITCH	YAW	ROLL	WARRANTY
27.52 x 4.88 x 27.27 in   699 x 124 x 693 mm	+6.00°/-6.00°	+360.00°/-360.00	+3.00°/-3.00°	Limited Lifetime

## PACKAGING

LENGTH x WIDTH x DEPTH	CONTENTS
15 x 6 x 20 in   381 x 152 x 508 mm	Universal Plate (x1), Universal Leg Assembly (x4), Base Box (x1), Universal Hardware Pack (x1)

## ARCHITECTURAL DRAWING

