

(FULLY EXTENDED)

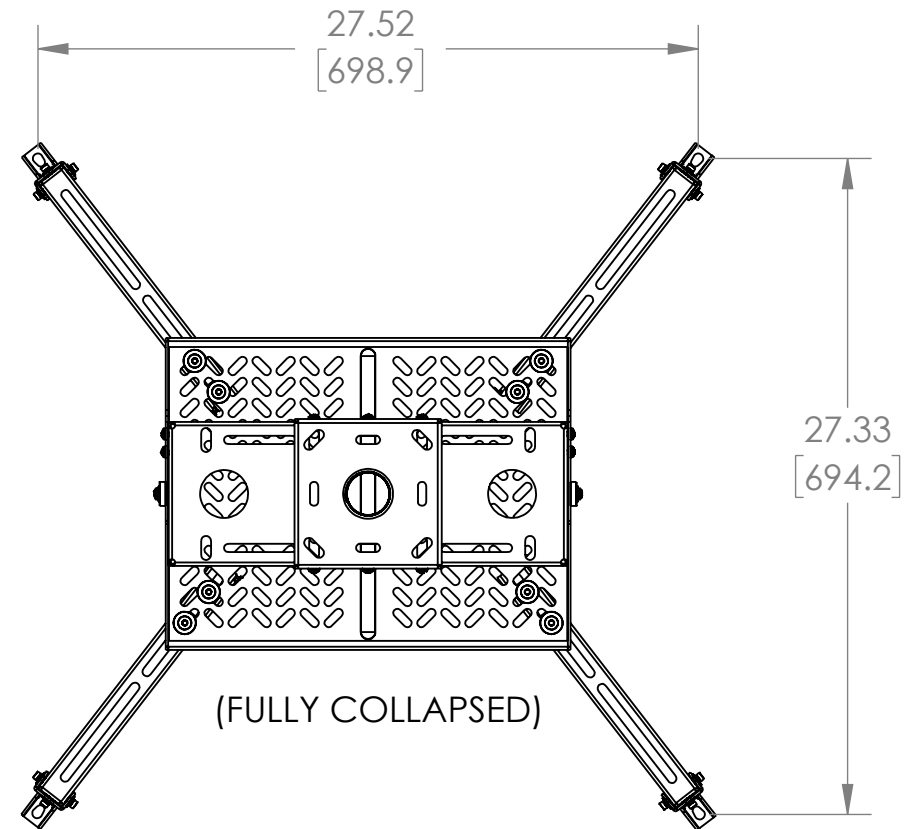

(FULLY COLLAPSED)

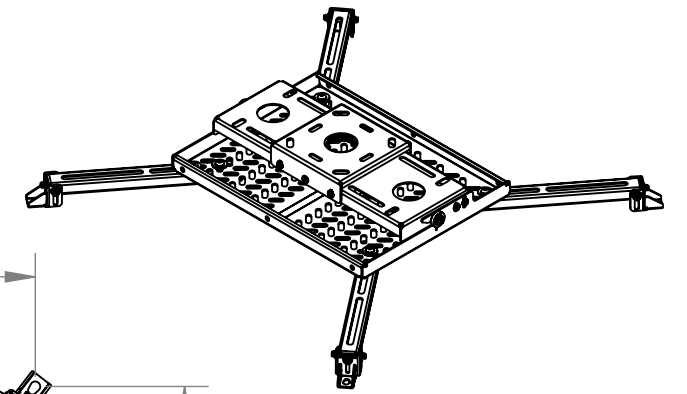

1.5" NPT PIPE
THREADS

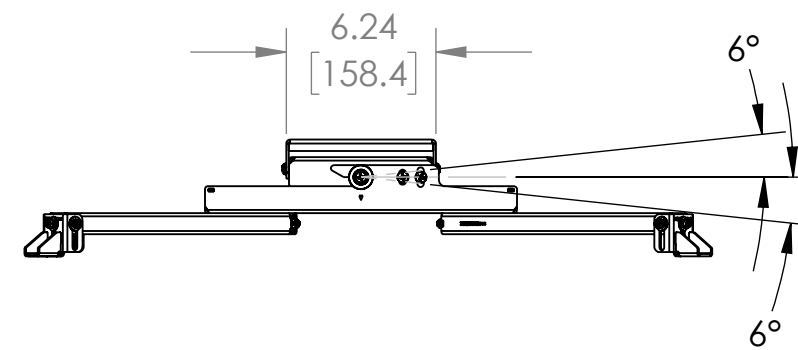
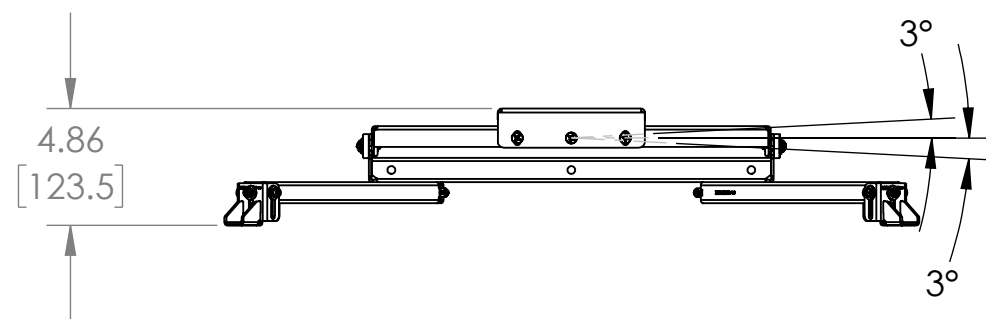

DESCRIPTION:			
HEAVY DUTY UNIVERSAL PROJECTOR MOUNT			
PART NO. PBM-UNI			
MAX. WEIGHT CAPACITY	DIMENSION ARE IN	SCALE:	SHEET
225.0 LB.	INCH AND [MM]	1:8	1 OF 1

