

# CTM-MS3 Installation Guide

Installationsanleitung, Guía de Instalación, Guida de Installazione, Guide d'Installation, Installatie gids

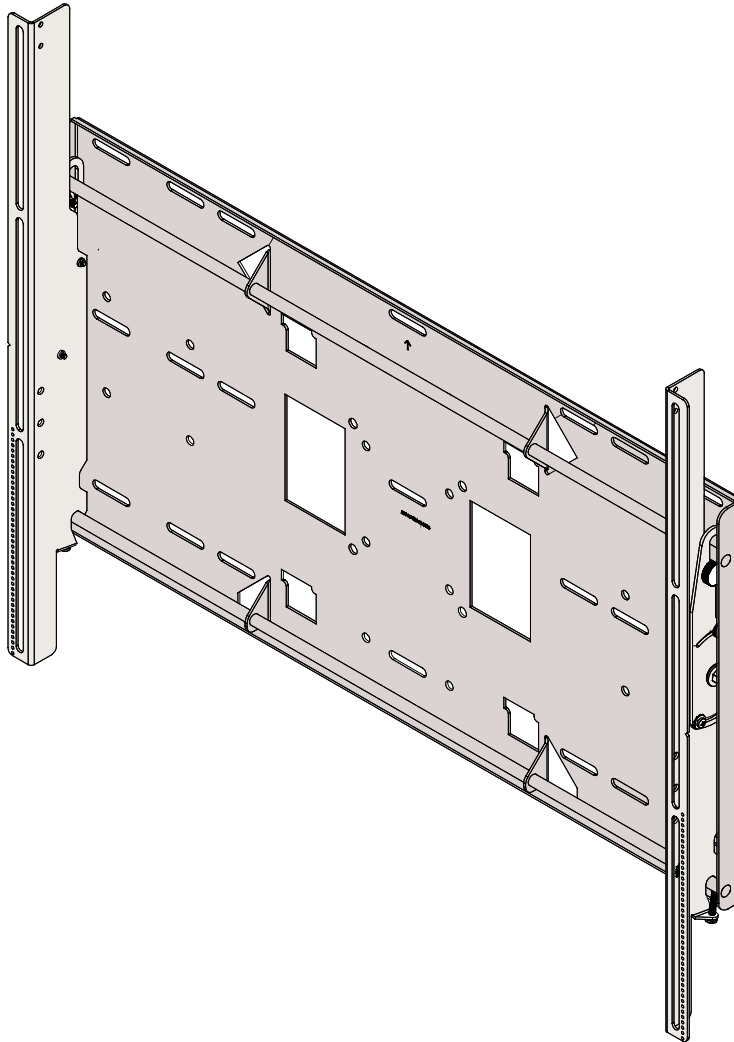

[premiermounts.com](http://premiermounts.com) | p. 800.368.9700 | e. [orders@premiermounts.com](mailto:orders@premiermounts.com)  
500 W Central Ave, Suite A, Brea, CA 92821 USA



## Weight Limit

Maximum Flat Panel Weight: **300 lbs.**

THE WALL STRUCTURE MUST BE CAPABLE OF SUPPORTING AT LEAST FOUR TIMES THE WEIGHT OF THE FLAT PANEL. IF NOT, THE WALL STRUCTURE MUST BE REINFORCED.

## Warning Statements



PRIOR TO THE INSTALLATION OF THIS PRODUCT, THE INSTALLATION INSTRUCTIONS MUST BE READ AND COMPLETELY UNDERSTOOD. KEEP THESE INSTALLATION INSTRUCTIONS IN AN EASILY ACCESSIBLE LOCATION FOR FUTURE REFERENCE.



PROPER INSTALLATION PROCEDURE BY A QUALIFIED SERVICE TECHNICIAN MUST BE FOLLOWED, AS OUTLINED IN THESE INSTALLATION INSTRUCTIONS. FAILURE TO DO SO COULD RESULT IN PROPERTY DAMAGE, SERIOUS PERSONAL INJURY, OR EVEN DEATH.



SAFETY MEASURES MUST BE PRACTICED AT ALL TIMES DURING THE ASSEMBLY OF THIS PRODUCT. USE PROPER SAFETY EQUIPMENT AND TOOLS FOR THE ASSEMBLY PROCEDURE TO PREVENT PERSONAL INJURY.



PREMIER MOUNTS DOES NOT WARRANT AGAINST DAMAGE CAUSED BY THE USE OF ANY PREMIER MOUNTS PRODUCT FOR PURPOSES OTHER THAN THOSE FOR WHICH IT WAS DESIGNED OR DAMAGE CAUSED BY UNAUTHORIZED ATTACHMENTS OR MODIFICATIONS, AND IS NOT RESPONSIBLE FOR ANY DAMAGES, CLAIMS, DEMANDS, SUITS, ACTIONS OR CAUSES OF ACTION OF WHATEVER KIND RESULTING FROM, ARISING OUT OF OR IN ANY MANNER RELATING TO ANY SUCH USE, ATTACHMENTS OR MODIFICATIONS.



At least two qualified people should perform the assembly procedure. Personal injury and/or property damage can result from dropping or mishandling the flat panel.



If mounting to wall studs or ceiling studs, make sure that the mounting screws are anchored into the center of the wall studs or ceiling studs. Use of an edge-to-edge stud finder is recommended.



It is recommended that a maximum of 5/8" plaster board be used when mounting to wooden studs.



Be aware of the mounting environment. If drilling and/or cutting into the mounting surface, always make sure that there are no electrical wires in wall. Cutting or drilling into an electrical line may cause serious personal injury.



Make sure there are no water or natural gas lines inside the wall where the mount is to be located. Cutting or drilling into a water or gas line may cause severe property damage or personal injury.



This product is intended for indoor use only. Use of this product outdoors could lead to product failure and/or serious personal injury.



Do not install near sources of high heat. Do not install on a structure that is prone to vibration, movement or chance of impact.

## AVERTISSEMENT



AVANT L'INSTALLATION DE CE PRODUIT, LES CONSIGNES D'INSTALLATION DOIVENT ÊTRE LUES ET PLEINEMENT COMPRISES. CONSERVER CES CONSIGNES D'INSTALLATION DANS UN ENDROIT FACILEMENT ACCESSIBLE POUR RÉFÉRENCE FUTURE.



LA PROCÉDURE D'INSTALLATION CORRECTE PAR UN TECHNICIEN QUALIFIÉ DOIT ÊTRE OBSERVÉE, COMME DÉCRIT DANS CES CONSIGNES D'INSTALLATION. FAUTE DE QUOI DES DOMMAGES MATÉRIELS, BLESSURES GRAVES, VOIRE MÊME LA MORT PEUT SUBVENIR.



DES MESURES DE SÉCURITÉ DOIVENT ÊTRE PRATIQUÉES À TOUT MOMENT DURANT L'ASSEMBLAGE DE CE PRODUIT. UTILISER L'ÉQUIPEMENT ET OUTILS DE SÉCURITÉ APPROPRIÉ POUR LA PROCÉDURE D'ASSEMBLAGE AFIN D'ÉVITER DES BLESSURES.



LES SUPPORTS PREMIER MOUNTS NE GARANTISSENT PAS CONTRE LES DOMMAGES CAUSÉS PAR L'USAGE DU PRODUIT DE MONTAGE PREMIER MOUNTS À D'AUTRES FINS QUE CELLES POUR LESQUELLES IL A ÉTÉ CONÇU OU DES DOMMAGES CAUSÉS PAR DES ACCESSOIRES OU DES MODIFICATIONS NON AUTORISÉS, ET NOUS NE POUVONS PAS ÊTRE TENUS RESPONSABLES DES DOMMAGES, PLAINTES, RÉCLAMATIONS, POURSUITES, ACTIONS OU CAUSES D'ACTION DE N'IMPORTE QUELLE MANIÈRE RÉSULTANT DE, DÉCOULANT DE OU TOUCHANT DE N'IMPORTE QUELLE MANIÈRE UN TEL USAGE, ACCESSOIRE OU MODIFICATION



Au moins deux personnes qualifiées devraient exécuter la procédure d'assemblage. Il pourrait subvenir des blessures et/ou des dommages matériels dû à la chute ou à la manipulation incorrecte de l'écran plat.



Si le montage s'effectue sur des rivets, assurez-vous que les vis de montage sont ancrées au centre des rivets. L'usage d'un détecteur de rivet bord-à-bord est recommandé.



Il est recommandé qu'un maximum de plaque-plâtre de 5/8" soit utilisé lors d'un montage sur des rivets à bois.



Familiarisez-vous avec l'environnement de montage. Si un perçage et/ou une coupe est opéré sur la surface de montage, assurez-vous toujours qu'il n'y a pas de fils électriques dans le mur. Couper/percer dans une installation électrique peut causer des blessures graves.



S'assurer qu'il n'y a pas de canalisation d'eau à l'intérieur du mur où le montage doit être localisé. Une coupe/perçage dans une canalisation d'eau peut causer sérieusement endommager le circuit d'eau au niveau de la surface de montage.



Ce produit n'est destiné qu'à être utilisé à l'intérieur. L'utilisation de ce produit à l'extérieur pourrait entraîner des défauts matériels et/ou des blessures graves.



Ne pas installer près de sources de forte chaleur. Ne pas installer sur une structure soumise aux vibrations, aux mouvements ou aux chocs.

# CTM-MS3 Installation Guide

Installationsanleitung, Guía de Instalación, Guida de Installazione, Guide d'Installation, Installatie gids



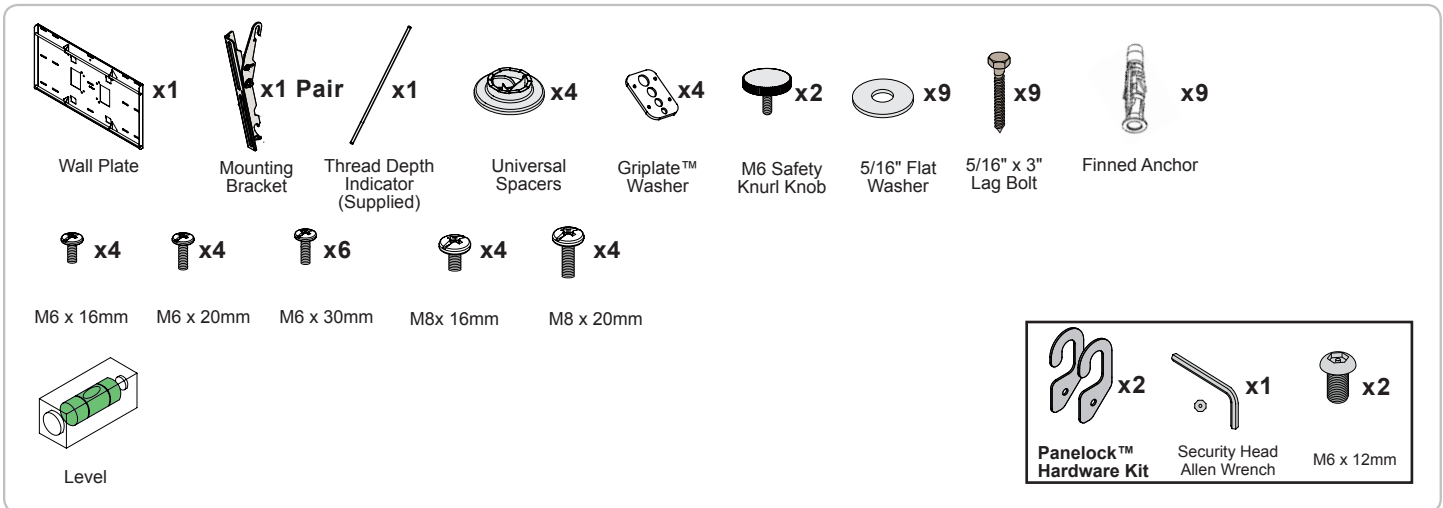

## Included components

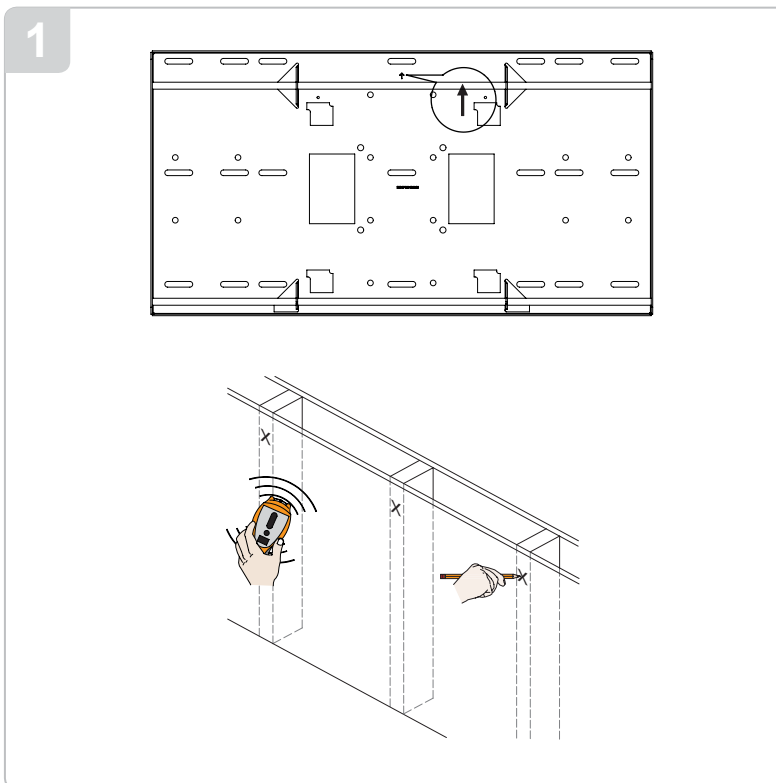

## Required for installation



## WOOD STUD INSTALLATION

-  Minimum of 2 x 4 wood stud to be used
  -  Minimum de 2 x 4 bois goujon pour être utilisé
  -  **Directional Mounting Arrow**  
 The Directional Mounting Arrow stamped into the CTM-MS3 wall plate indicates which edge is the top.
  -  **Visual Centering Diamond**  
 The Visual Centering Diamond will guide you in determining the screen placement on the wall.
  -  **Mounting Safety**  
 Two people are recommended to install the wall plate.
  -  Il est recommandé deux personnes pour l'installation de ce support.
  -  You must secure the wall plate to three (3) wall studs with a minimum of nine (9) lag bolts (3 lag bolts for each stud found)
  -  Vous devez assembler la sablière sur trois (3) rivets de mur avec un minimum de neuf (9) tirefonds (3 tirefonds pour chaque rivet trouvé).
- 1) Use a stud finder to determine the exact center of wall studs in the vicinity of the wall plate.
  - 2) Use a pencil to mark the exact center of each of the wall studs.





# CTM-MS3

## Installation Guide

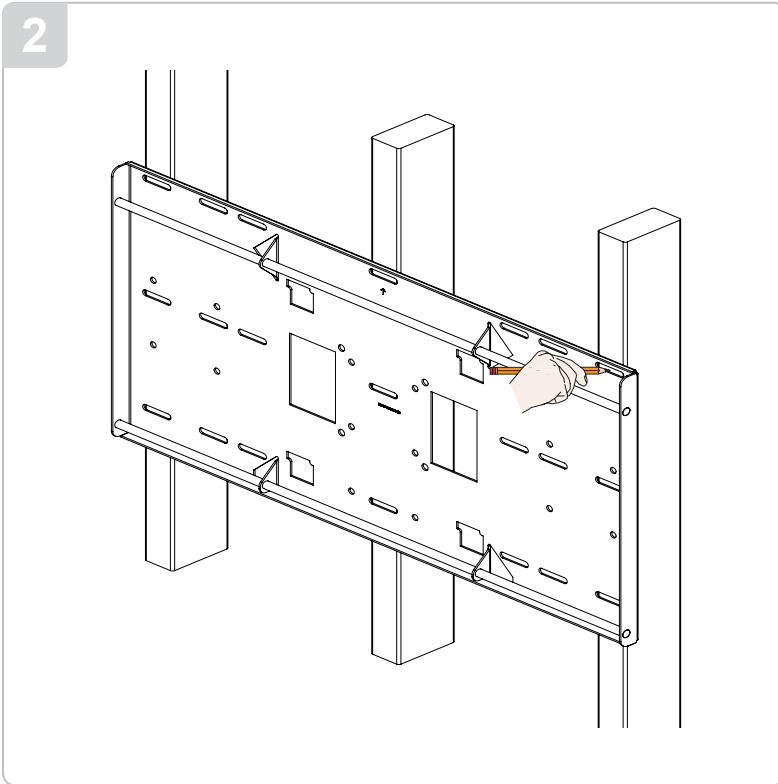
Installationsanleitung, Guía de Instalación, Guida de Installazione, Guide d'Installation, Installatie gids



 Two people are recommended for this step; one person to level the wall plate and another person to mark the wall stud location.

 Il est recommandé deux personnes pour cette étape : une personne pour niveler la sablière et une autre personne pour marquer l'emplacement de l'ossature murale à claire-voie.

- 1) Place the wall plate against the wall in the desired viewing location.
- 2) Adjust the wall plate to align the mount slots in the wall plate with the center of the wall studs.
- 3) Use a pencil to mark the upper right mounting location along the center of the wall stud.

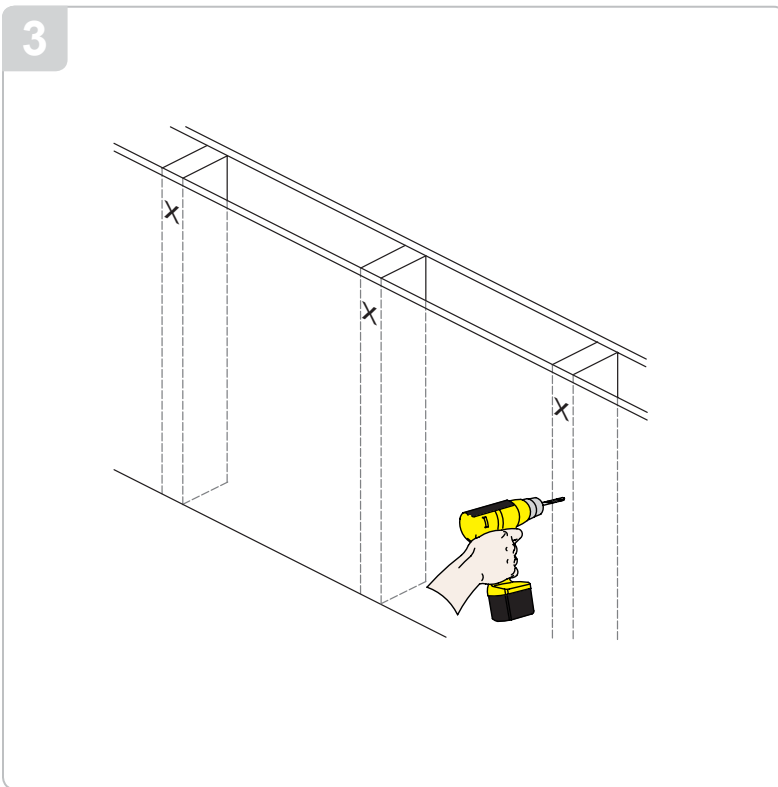

Drill a "pilot hole" in the center of the upper right mark using a 1/4" drill bit and power drill.

 Only use a 1/4" drill bit when drilling pilot holes.

 N'utiliser qu'un foret de 1/4" lors du forage de guidage.



# CTM-MS3 Installation Guide

Installationsanleitung, Guía de Instalación, Guida de Installazione, Guide d'Installation, Installatie gids

4

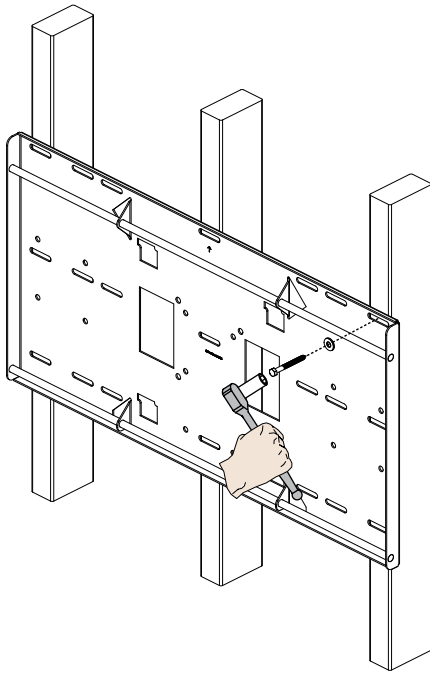

- 1) Place the wall plate against the wall and align it with the pilot hole.
- 2) Insert one (1) 5/16" x 3" lag bolt and one (1) 5/16" washer into the upper right pilot hole.
- 3) Use a socket wrench and a 1/2" socket to tighten the lag bolt.

 Do not over tighten the lag bolt.

 Éviter de trop serrer les tirefonds.

5

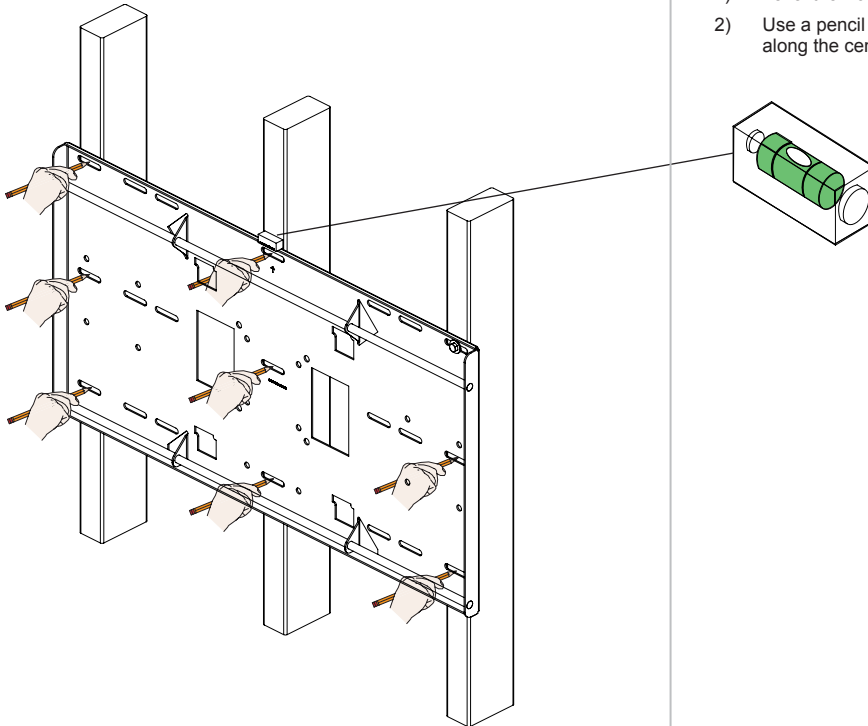

- 1) Level the wall plate.
- 2) Use a pencil to mark the remaining eight (8) mounting locations along the center of each wall stud.



# CTM-MS3



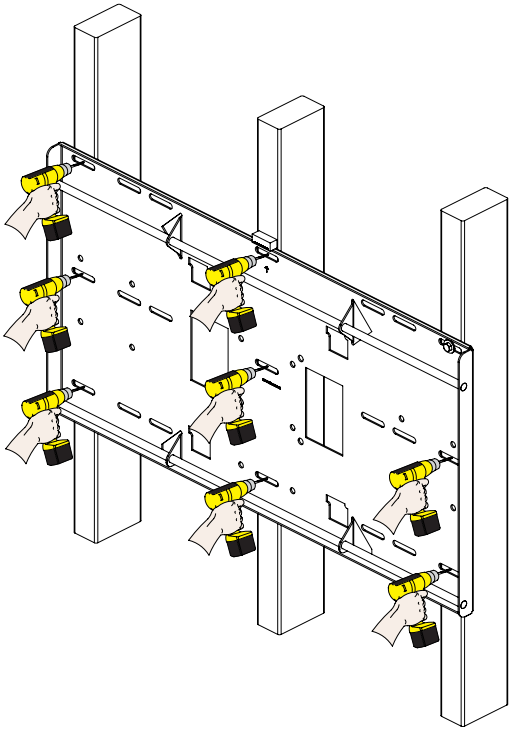

## Installation Guide

Installationsanleitung, Guía de Instalación, Guida de Installazione, Guide d'Installation, Installatie gids

6





Drill a "pilot hole" in the center of each of the marks with a power drill and a 1/4" drill bit.

-  Two people are recommended for this step; one person to level the wall plate and another person to drill the pilot holes.
-  Il est recommandé deux personnes pour cette étape : une personne pour niveler la sablière et une autre personne pour percer le forage de guidage.
-  Only use 1/4" drill bit when drilling the pilot holes.
-  N'utiliser qu'un foret de 1/4" lors du forage de guidage.

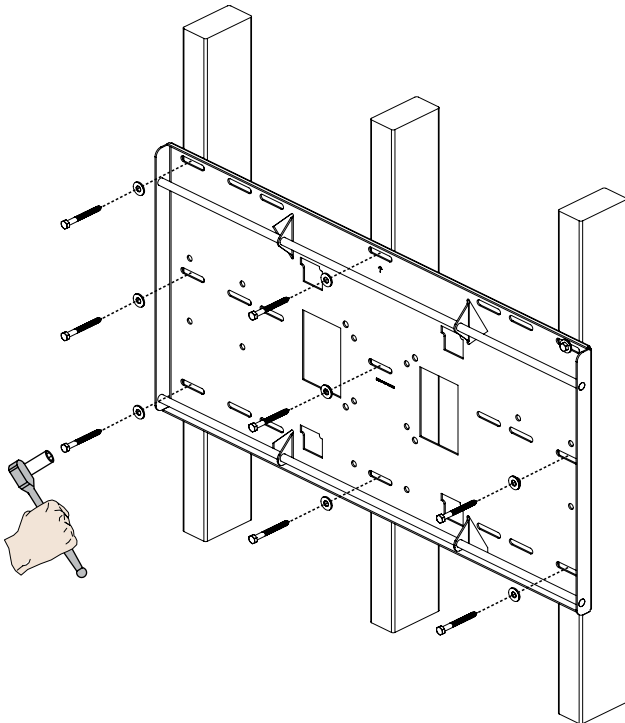
7



- 1) Insert one (1) 5/16" x 3" lag bolt and one (1) 5/16" washer into each pilot hole
- 2) Tighten all lag bolts using a socket wrench and 1/2" socket.

-  Do not over tighten the lag bolts when attaching the mount to the wall. Improper installation may result in personal injury or property damage.
-  Éviter de trop serrer les tirefonds lors de la fixation du support au mur. Une installation incorrecte peut entraîner des blessures ou des dommages matériels.



# CTM-MS3 Installation Guide

Installationsanleitung, Guía de Instalación, Guida de Installazione, Guide d'Installation, Installatie gids

## CONCRETE WALL INSTALLATION

8

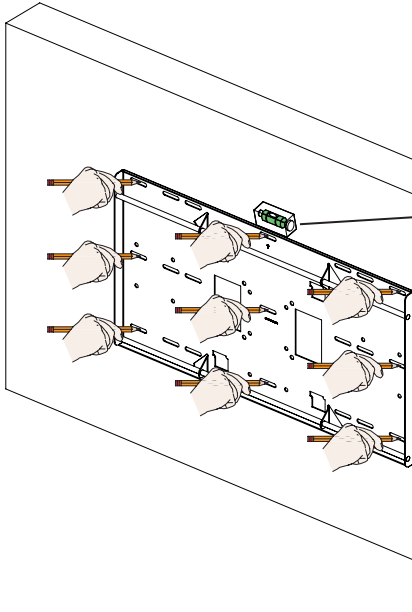

Two people are recommended for this step: one person to level the wall plate and another person to mark the mounting locations.



Il est recommandé deux personnes pour cette étape : une personne pour niveler la sablière et une autre personne pour marquer les emplacements de montage.

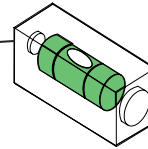

9

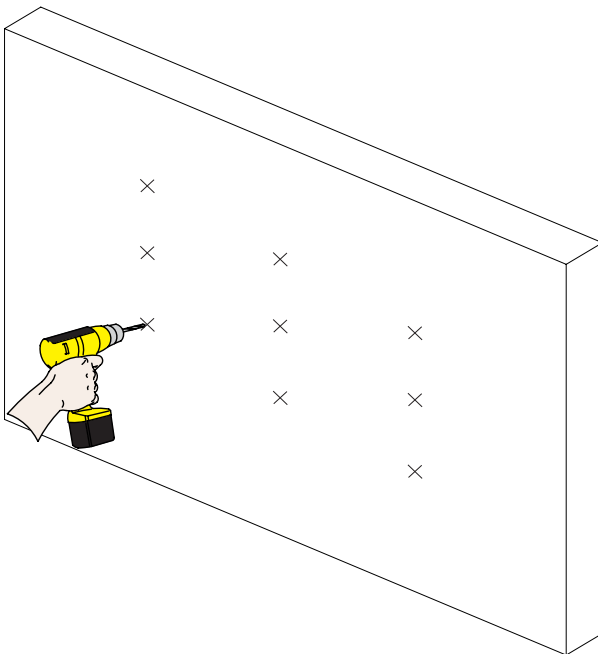

Drill nine (9) pilot holes of each mark using a drill and 3/8" masonry drill bit. Drill 3 inches deep.



Only use a 3/8" masonry drill bit when drilling pilot holes.



N'utiliser qu'un foret de 3/8" lors du forage de guidage.



# CTM-MS3

## Installation Guide

Installationsanleitung, Guía de Instalación, Guida de Installazione, Guide d'Installation, Installatie gids

10

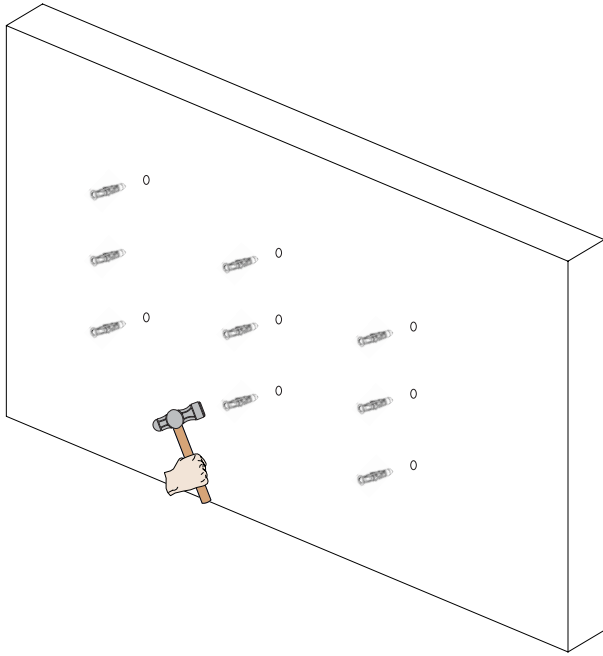

Insert a Finned Anchors into each hole. Lightly tap each Finned Anchors into place with a hammer.

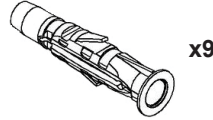

11

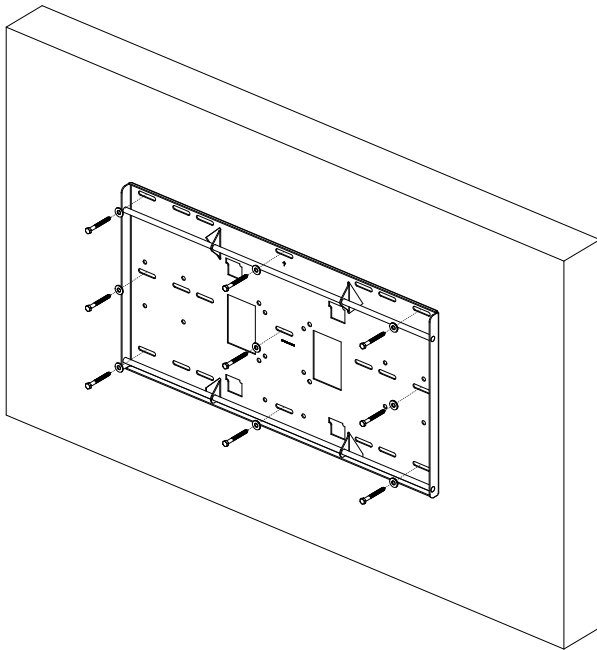

Insert the lag bolts and washers into the Finned Anchors. Tighten all lag bolts using a socket wrench and 1/2" or 13mm socket.

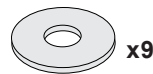

**5/16" Flat Washer**

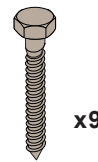

**5/16" x 3" Lag Bolt**



Do not over tighten the lag bolts.



Éviter de trop serrer les tirefonds.





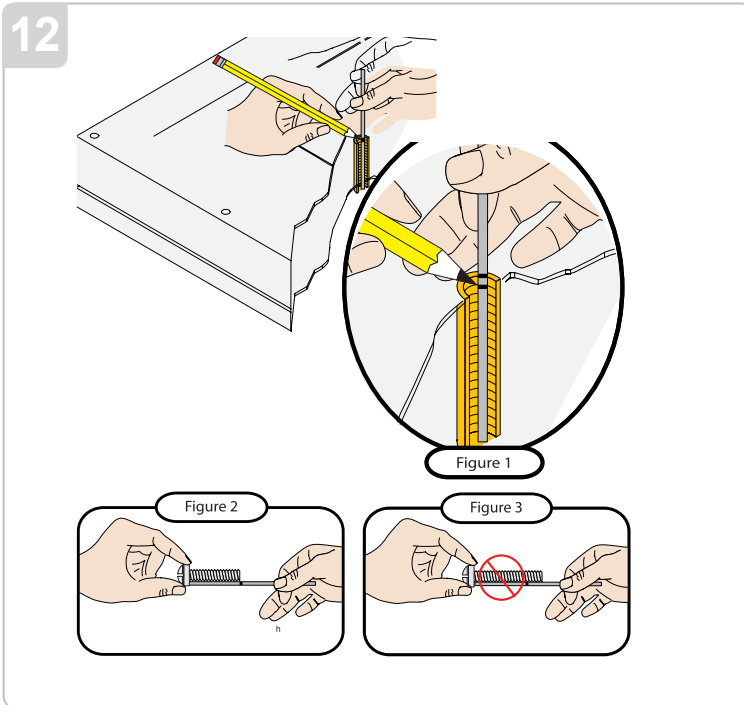

## Selecting the Mounting Hardware





- 1) Insert a small straw or toothpick into the threaded inserts found on the back of the flat panel.
- 2) Use a pencil to mark the depth of the threaded insert on the small straw or toothpick.
- 3) Mark the straw or toothpick 1/8" above the depth of the threaded insert, as shown in Figure 1.
- 4) Insert the small straw or toothpick into the remaining threaded inserts to compare and verify their depth using the straw or toothpick's 1/8" allowance mark.
- 5) Locate the correct diameter screw for the threaded insert.

 If the screw you selected is longer than the 1/8" allowance mark on the small straw or toothpick, as shown in Figure 2 and Figure 3, do not use this screw. The screw length must not bypass the mark.

 Si la vis que vous sélectionnez est plus longue que la marque de jeu maximal de 1/8" sur le pailon ou le cure-dents, comme illustré sur le schéma 2 et le schéma 3, veuillez ne pas utiliser cette vis. La longueur de la vis doit dévier la marque.

- 6) Test each size of the screws provided.

 The correct screws should thread easily into the mounting point and not pull out when tension is applied.

 Les vis corrects devraient enfler facilement dans le point de fixation et sortir pas lorsqu'une tension est appliquée.

## Universal Spacer Installation

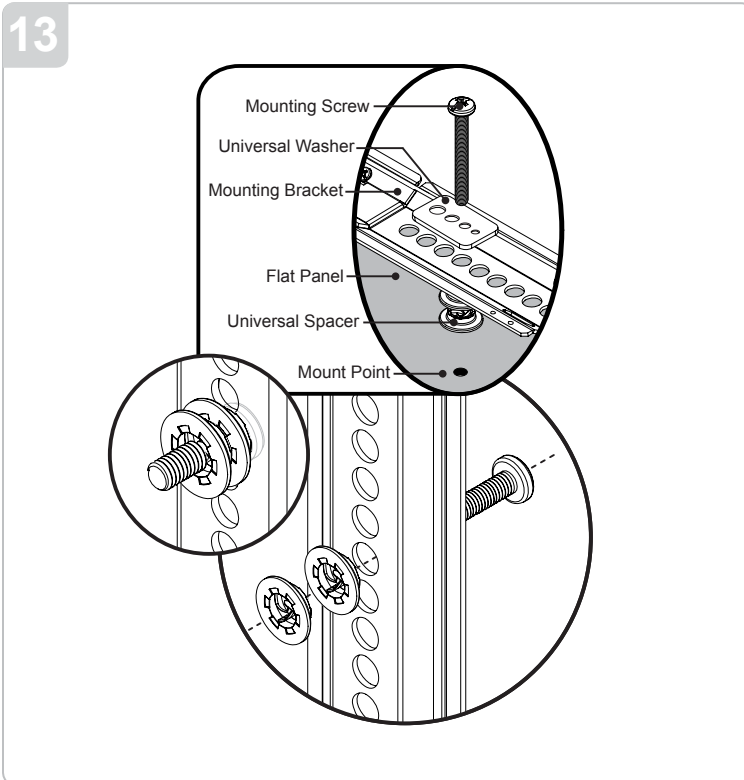

Premier Mounts' Universal Spacers allow you to attach the mounting bracket to flat-panels which have recessed or uneven mount points. Each Universal Spacer adds 1/4" to the distance between the mounting bracket and your flat-panel.

 The Universal Spacers must be stacked and oriented as shown.

 The Universal Spacers must only be installed between the mounting bracket and your flat-panel.

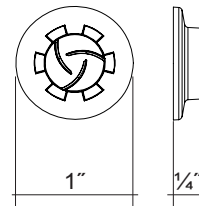

# CTM-MS3

## Installation Guide

Installationsanleitung, Guía de Instalación, Guida de Installazione, Guide d'Installation, Installatie gids

### Universal Washer Installation

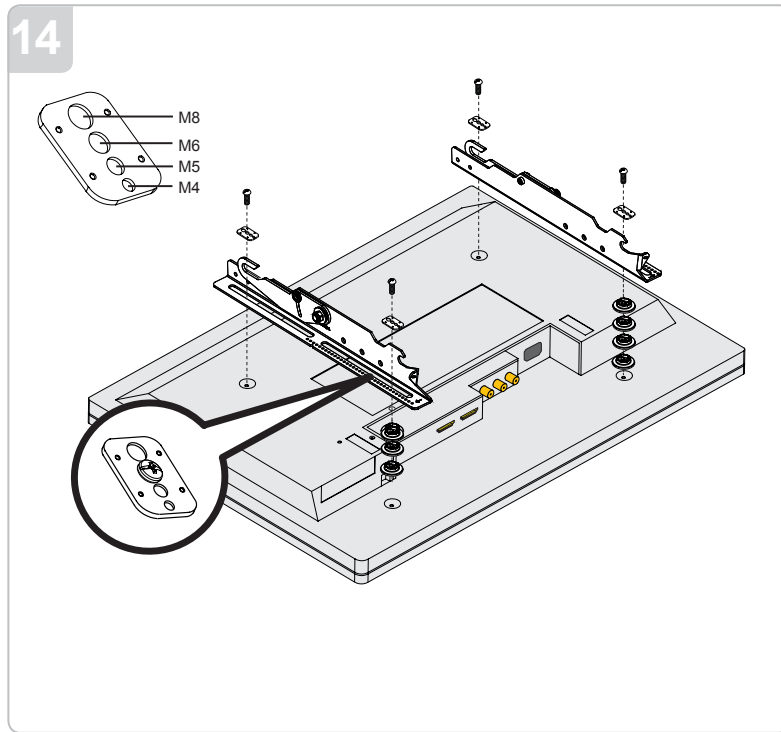

Premier Mounts' Universal Washers are designed to accommodate the various M4, M5, M6 and M8 hole sizes required by flat-panels.



Do not place excessive pressure on the back of the flat-panel, as this may damage your flat-panel.



The Universal Washer must be installed between the head of the mounting screw and the mounting bracket as shown.

- 1) Place your flat panel screen-side down on a soft, flat surface.
- 2) Identify the number and location of the thread inserts on the back of your flat panel.
- 3) Aligning the holes on each mounting bracket with the thread inserts on the back of your flat panel.
- 4) Secure each mounting bracket to your flat panel by inserting a minimum of two (2) screws per bracket.



Do not overtighten the mounting hardware.



Éviter de trop serrer le dispositif de montage.

### Attaching the Flat Panel to the Mount

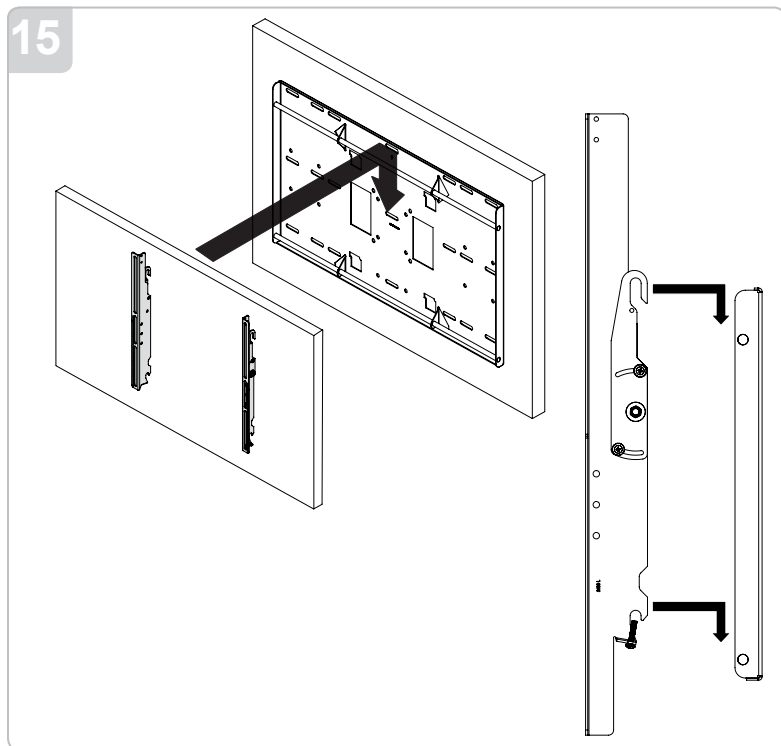

This section requires two people.



Cette section exige deux personnes.



Do not release your flat panel until you are certain that top and bottom hooks of both mounting brackets are securely seated on the upper and lower mounting rails of the wall panel.



Éviter de relâcher votre écran plat jusqu'à ce que vous vous assuriez que les crochets de haut et de bas de tous les deux supports de montage sont bien posés sur les rails de montage hauts et bas de la sablière.

- 1) Raise the flat panel past the top and bottom mounting rails on the wall panel.
- 2) Slide the flat panel down slowly, keeping it close to the wall.
- 3) Engage the top and bottom mounting brackets to the rails of the wall plate.



# CTM-MS3 Installation Guide

Installationsanleitung, Guía de Instalación, Guida de Installazione, Guide d'Installation, Installatie gids

## Safety Knurl Knob Installation

16

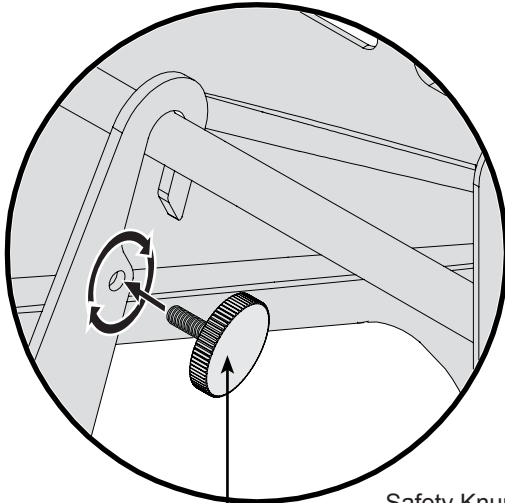

Safety Knurl Knob  
(1 per Bracket)

 If you chose not to install the safety knurl knobs and instead chose to use the Panelock™, skip this section and proceed to the Panelock™ Installation section below.

The Panelock™ is a theft deterrent device. It comes with security hardware that requires a special tool that is used to install and remove the security head screws.



The safety knurl knobs keep the flat panel from being accidentally dislodged from the CTM-MS3.



Les boutons de molettes de sécurité maintiennent le panneau plat d'être accidentellement délogé du CTM-MS3.

- 1) Fully extend the flat panel away from the wall.
- 2) Install and tighten a safety knurl knob at the top of one of the mounting brackets.
- 3) Repeat steps 1 and 2 for the other safety knurl knob.

## Panelock™ Installation

17

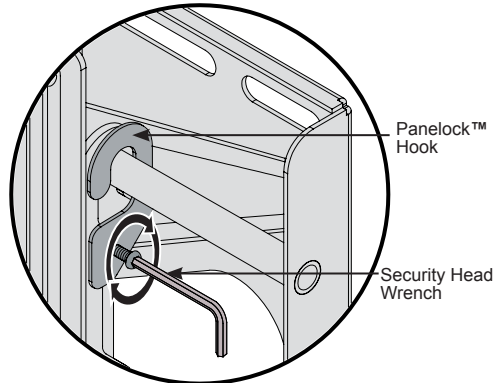
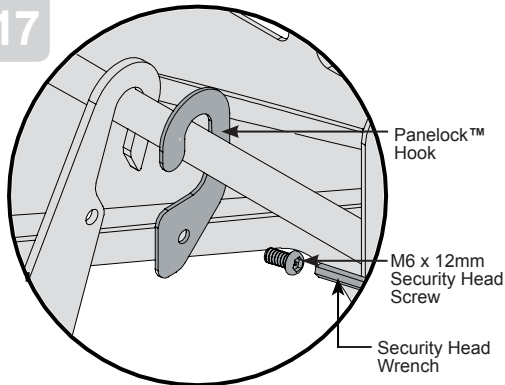

If the safety knurl knobs were previously installed, they must be removed prior to installing the Panelock™ hardware.



Be sure that the Panelock™ is facing in the same direction as shown in the illustration to the right.

- 1) Slide the Panelock™ onto the top mounting rail, placing the Panelock™ to the outside edge of the flat panel bracket.
- 2) Insert and tighten one (1) M6 x 12mm screw to attach the Panelock™ to the flat panel bracket.



Repeat steps 1 and 2 to attach the remaining Panelock™.



# CTM-MS3

## Installation Guide

Installationsanleitung, Guía de Instalación, Guida de Installazione, Guide d'Installation, Installatie gids

### Locking Safety Screw Installation

18

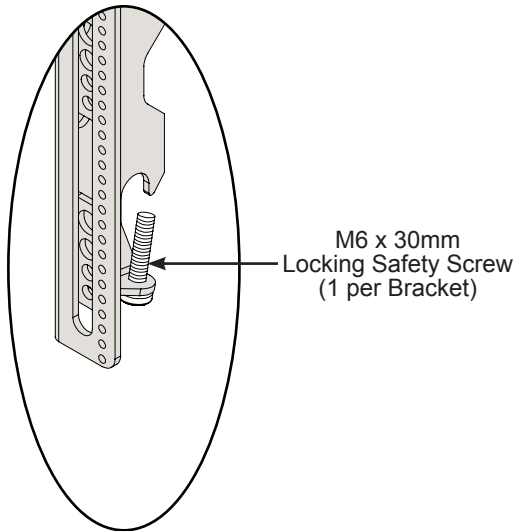

 The locking safety screws keep the flat panel from being accidentally dislodged from the CTM-MS3.

 Les boutons de molettes de sécurité maintiennent le panneau plat d'être accidentellement délogé du CTM-MS3.

- 1) Thread an M6 x 30mm locking safety screw at the bottom of one of the mounting brackets.
- 2) Use a Phillips head screwdriver to tighten the locking safety screw.
- 3) Repeat steps 1 and 2 for the other locking safety screw.

 Do not overtighten the locking safety screws.

 Éviter de trop serrer les vis de blocage.

### Tilting Adjustment

19

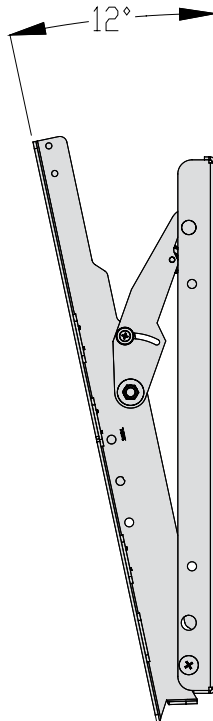

#### **Adjusting the Flat Panel Friction Tilt Angle**

- 1) Place one hand at the center top edge of the flat panel.
- 2) Place the other hand on the center bottom edge of the flat panel.
- 3) Using the upper hand, gently pull the top of the flat panel towards you while the lower hand gently pushes the bottom of the flat panel away from you.

#### **Adjusting the Flat Panel to the Original Position**

- 1) Place one hand at the center top edge of the flat panel.
- 2) Place the other hand on the center bottom edge of the flat panel.
- 3) Using the upper hand, gently push the top of the flat panel towards the wall while the lower hand gently pulls the bottom of the flat panel away from the wall.

