

# PBM-UNI

## Installation Guide

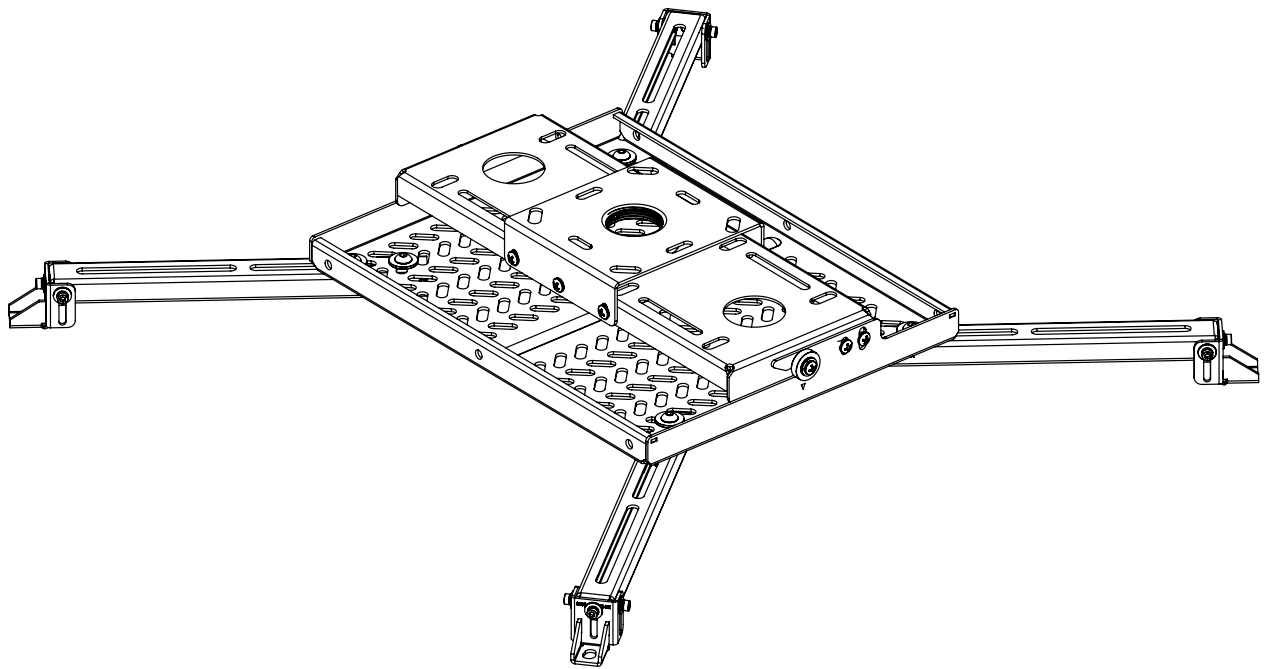

[premiermounts.com](http://premiermounts.com) | p. 800.368.9700 | e. [orders@premiermounts.com](mailto:orders@premiermounts.com)  
500 W Central Ave, Suite A, Brea, CA 92821 USA

## Warning Statements

**Warning** THE CEILING STRUCTURE MUST BE CAPABLE OF SUPPORTING AT LEAST FOUR (4) TIMES THE WEIGHT OF THE PROJECTOR. IF NOT, THE CEILING MUST BE REINFORCED. PROPER INSTALLATION PROCEDURE BY A QUALIFIED SERVICE TECHNICIAN, AS OUTLINED IN THE INSTALLATION INSTRUCTIONS, MUST BE ADHERED TO. FAILURE TO DO SO COULD RESULT IN SERIOUS PERSONAL INJURY, OR EVEN DEATH.

**Warning** SAFETY MEASURES MUST BE PRACTICED AT ALL TIMES DURING THE INSTALLATION OF THIS PRODUCT. USE PROPER SAFETY GEAR AND TOOLS FOR THE INSTALLATION PROCEDURE TO PREVENT PERSONAL INJURY.

**Warning** PRIOR TO THE INSTALLATION OF THIS PRODUCT, THE INSTALLATION INSTRUCTIONS SHOULD BE READ AND COMPLETELY UNDERSTOOD. THE INSTALLATION INSTRUCTIONS MUST BE READ TO PREVENT PERSONAL INJURY AND PROPERTY DAMAGE. KEEP THESE INSTALLATION INSTRUCTIONS IN AN EASILY ACCESSIBLE LOCATION FOR FUTURE REFERENCE.



Indicate that the power plug is to be disconnected from the power outlet.



Safety precautions must be taken at all times.



Warning and Caution statements.



A secure structure must support the weight, or load, or projector. When mounting to a ceiling that contains wooden studs, dead center of the wooden stud must be confirmed prior to installation.



Do not Install on a structure that is prone to vibration, movement or chance of impact. Failure to do so could result in damage to the projector and/ or damage to the mounting surface.



Do not install near heater, fireplace, direct sunlight, air conditioning or any other source of direct heat energy. Failure to do so may result in damage to the projector and could increase the risk of fire.



At least two qualified people should perform the installation procedure. Injury and/or damage can result from dropping or mishandling projector.



Recommended mounting surfaces: wooden studs and solid-flat concrete. If the mount is to be installed on any surface other than wooden studs, use suitable hardware (which is commercially



## Included components

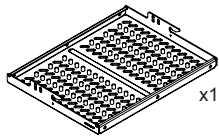

Universal Plate

x1

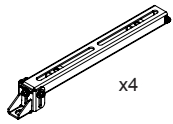

Universal Leg Assembly

x4

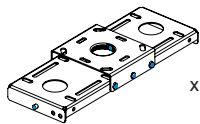

Base Box

x1



M3 Allen Key

x1



M4 Allen Key

x1



M5 Allen Key

x1



M6 x 12mm

x10



M6 x 16mm

x4



M6 x 20mm

x4



M6 x 30mm

x4



M8 x 12mm

x4



M8 x 16mm

x4



M8 x 20mm

x4



M8 x 30mm

x4



M10 x 12mm

x4



M10 x 30mm

x4



M8 x 20mm Button Hex Screw

x8



M8 Large Washer

x8



Nylon Spacer

x2



1/4" Washer

x2



M6 x 8 mm Set Screws

x1



Lock Nut

x1



M6 Washer

x4



5/16" Washer

x4



Universal Spacer

x8

## Universal Leg Assembly Adjustments

The Universal Leg Assembly can be adjusted for uneven surfaces. Loosen the three (3) socket cap screw shown below with the supplied M4 Allen Key.

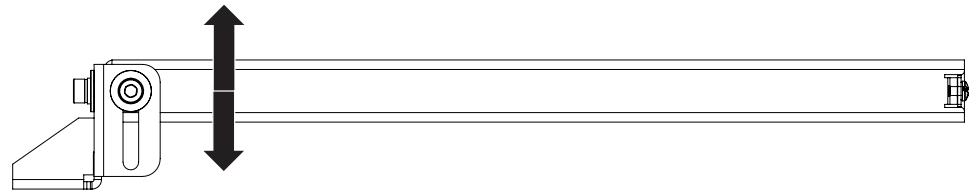
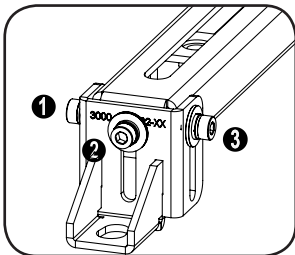

1

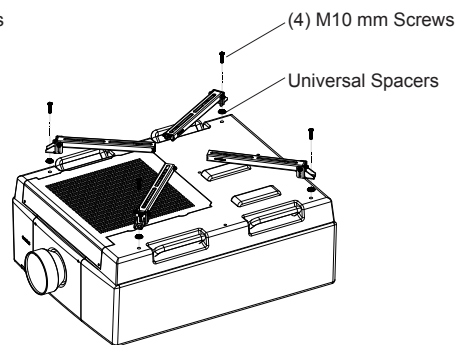
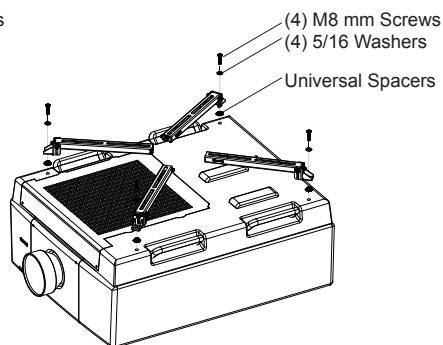
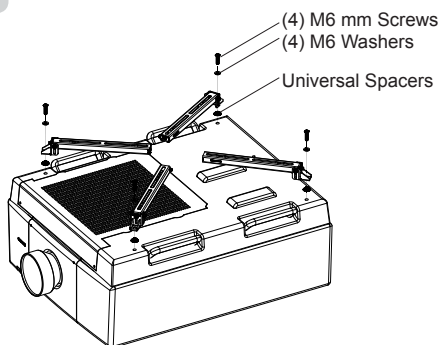

Install four (4) Universal Leg Assembly's using four (4) M6, M8, or M10mm screws depending on projector.

### Note

- 1) Use washers for M6 and M8 mm screws shown above.
- 2) Use Universal Spacers if necessary.



# PBM-UNI

## Installation Guide

2

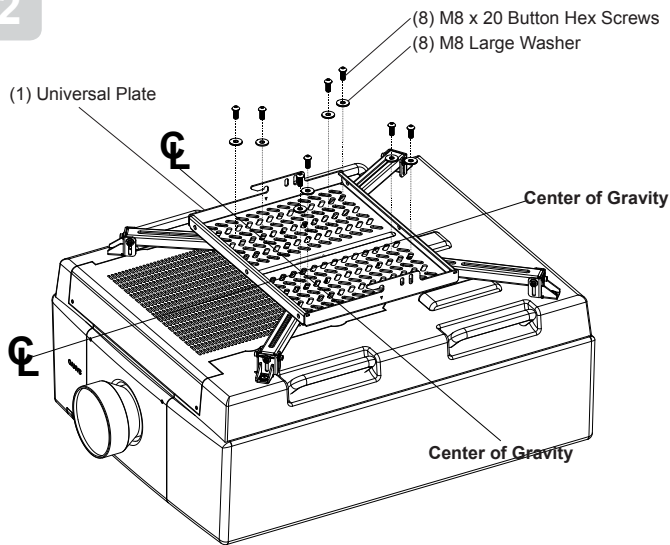

Install the Universal Plate to the Universal Leg Assembly's using eight (8) M8 x 20 Button Hex Screws and eight (8) M8 Large Washers. Tighten the M8 x 20 Button Hex Screws using the supplied M5 Allen Key.

### Note

It is important to install the Universal Plate to the Center of Gravity as close as possible.

3

### Wood Ceiling Installation

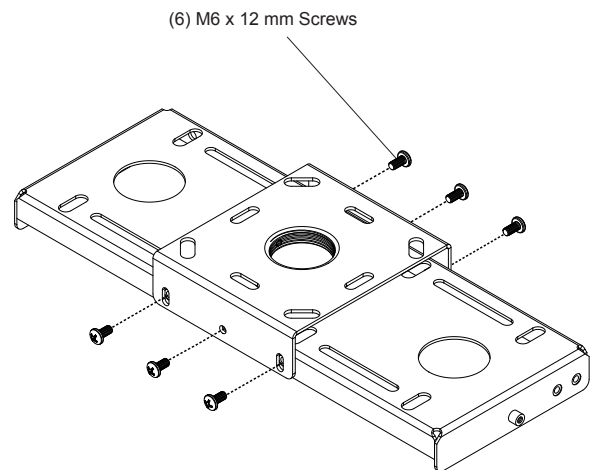

Disassemble the upper and lower base box by removing the six (6) M6 x 12 mm screws. Place the screws aside.

4

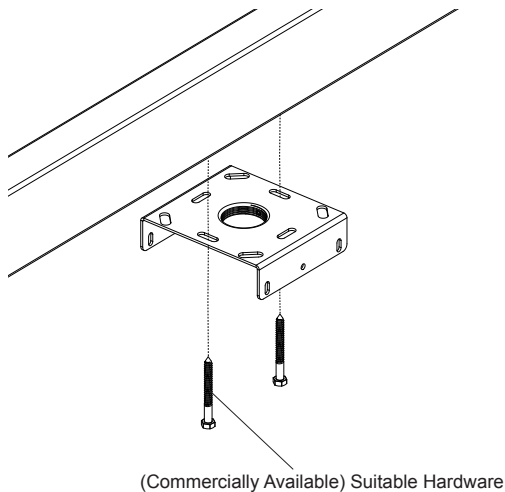

Secure the upper base box using two (2) commercially available hardware.

5

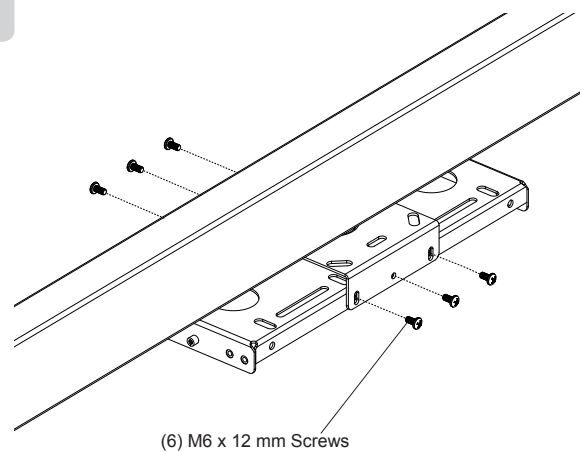

Install the upper and lower base box together by using the six (6) M6 x 12 mm screws disassembled on steps 3.



## 6 Pipe Ceiling Installation

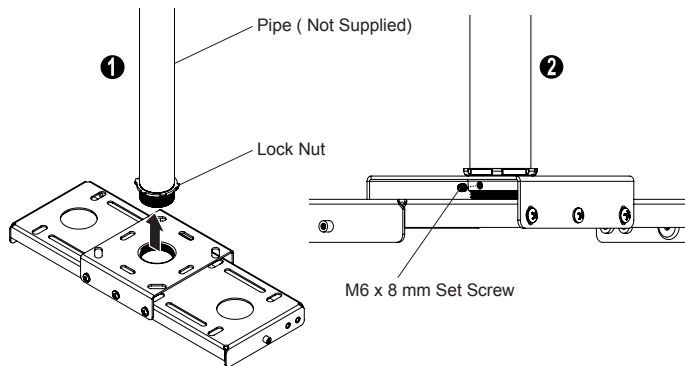

- 1) Install the base box to the pipe. Make sure the Lock Nut is on the pipe before installing the base box.
- 2) Secure the base box to the pipe by installing the M6 x 8 mm Set Screw using the M3 Allen Key

## 7

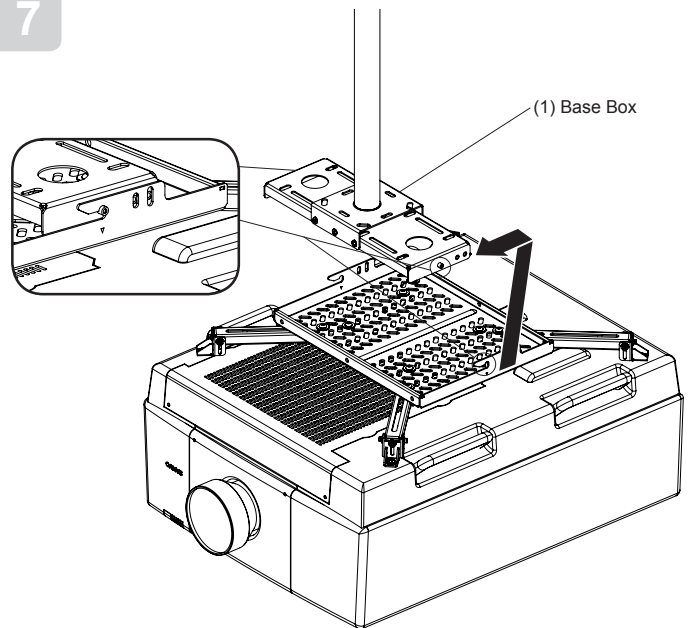

Raise the projector to the base box and hook it onto the base box. Make sure the projector is hooked onto both sides.

## 8

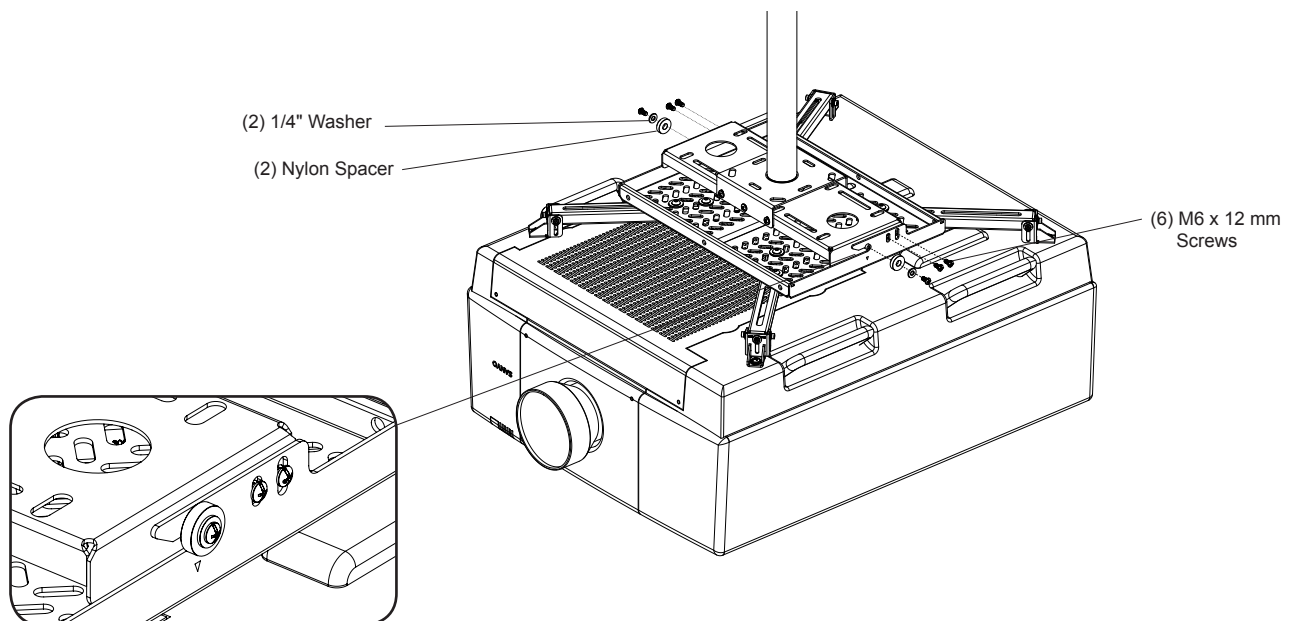

Secure the projector to the base box using six (6) M6 x 12 mm screws, two (2) nylon spacers, and two (2) 1/4" washers. Make final adjustment roll, yaw, pitch then tighten screws.



## PREMIER MOUNTS LIMITED LIFETIME WARRANTY

### What and Who is Covered by this Limited Lifetime Warranty

Premier Mounts warrants all mounting products to be free from defects in material and workmanship for the lifetime of the original installation of the product.

### What Premier Mounts Will Do

At the sole option of Premier Mounts, Premier Mounts will repair or replace any product or product part that is defective. If Premier Mounts chooses to replace a defective product or part, a replacement product or part will be shipped to you at no charge, but you must pay any related labor costs.

### What is Not Covered: Limitations

Premier Mounts disclaims any liability for damage to mounts, adapters, displays, projectors, other property, or personal injury resulting, in whole or in part, from improper installation, modification, use or misuse of its products.

NOTWITHSTANDING ANYTHING TO THE CONTRARY IN THIS WARRANTY, THIS WARRANTY IS LIMITED TO FIVE YEARS FROM THE DATE OF PURCHASE IN THE EVENT THAT THE WARRANTED PRODUCT IS COMMERCIALY RENTED OUT.

Electrical products and components, such as amplifiers, speakers, motors, switches remote controls and related electrical items, are backed by a 3-year warranty.

Premier Mounts disclaims all other warranties, express or implied, including warranties of merchantability and fitness for a particular purpose. Premier Mounts is not responsible for incidental or consequential damages, including but not limited to, inability to use its products or labor costs for removing and replacing defective products or parts. Some states do not allow the exclusion or limitation of incidental or consequential damages, so the above limitation or exclusion may not apply to you.

### What Customers Must Do for Warranty Service

If you discover a problem that you think may be covered by the warranty, you must report it in writing to the address below within thirty (30) days. Proof of purchase (an original sales receipt) from the original consumer purchaser must accompany all warranty claims. Warranty claims must also include a description of the problem, the purchaser's name, address, and telephone number. General inquiries can be addressed to Premier Mounts Customer Service at 1-800-368-9700. Warranty claims will not be accepted over the phone or by fax.

### PREMIER MOUNTS

#### ATTN: Warranty Claims

500 W Central Ave, Suite A  
Brea, CA 92821

### How State Law Applies

This warranty gives you specific legal rights, and you may also have other rights which vary from state to state.

Premier Mounts intends to make this manual accurate and complete. However, Premier Mounts makes no claim that the information contained herein covers all details, conditions or variations, nor does it provide for every possible contingency in connection with the installation or use of this product. The information contained in this document is subject to change without notice or obligation of any kind. Premier Mounts makes no representation of warranty, expressed or implied, regarding the information contained herein. Premier Mounts assumes no responsibility for accuracy, completeness or sufficiency of the information contained in this document.

### ©PREMIER MOUNTS

500 W Central Ave, Suite A  
Brea, CA 92821

### USA & CANADA

Phone: 800-368-9700

Fax: 800-832-4888

e. [orders@premiermounts.com](mailto:orders@premiermounts.com)

