



UNISTRUT ATTACHED FLAT PANEL MENU BOARD MOUNTING SOLUTION

Model: **UMB-DBT**

WEIGHT CAPACITY: 75 LBS / 34 KG

FEATURES

- 1** Attaches to commercially available slotted channel strut
- 2** Simple design for rapid install for less downtime
- 3** 0-15° degrees of locking tilt ensures uniform screen angles
- 4** Adjustable foot pads to overcome uneven walls

The UMB-DBT & UMB-DBTS menu board flat panel display brackets are a “no assembly required” system where, out of the box, brackets that hang on the panels and are designed to attach direct to slotted channel strut offering a quick and simple way to install a linear row of displays. This technology, along with less components, enables a fast, hassle-free installation process and a number of configuration options.



Installation safely secures digital signage in place



Allows video walls and digital displays to be positioned flat or up to 15 degrees



The most cost-effective digital menu board mounts on the market today

UNISTRUT ATTACHED FLAT PANEL MENU BOARD MOUNTING SOLUTION
UMB-DBT



SPECIFICATIONS

Weight 7lbs / 3.17 kg	Color Black	Weight Capacity / Mount 75 lbs. 34 kg	Mounting Pattern 200 x 200 mm (min) x 400 x 400 mm (Max)
Width x Height x Depth 16.5 x 2.63 x 1.9 in 419 x 66.6 x 48.3 mm		Warranty Lifetime	

PACKAGING

Width x Height x Depth 23-3/4 x 6-7/8 x 3 3/8 603.3 x 174.6 x 85.7 mm

Contents Adapter Arms (x 2)

ARCHITECTURAL DRAWING

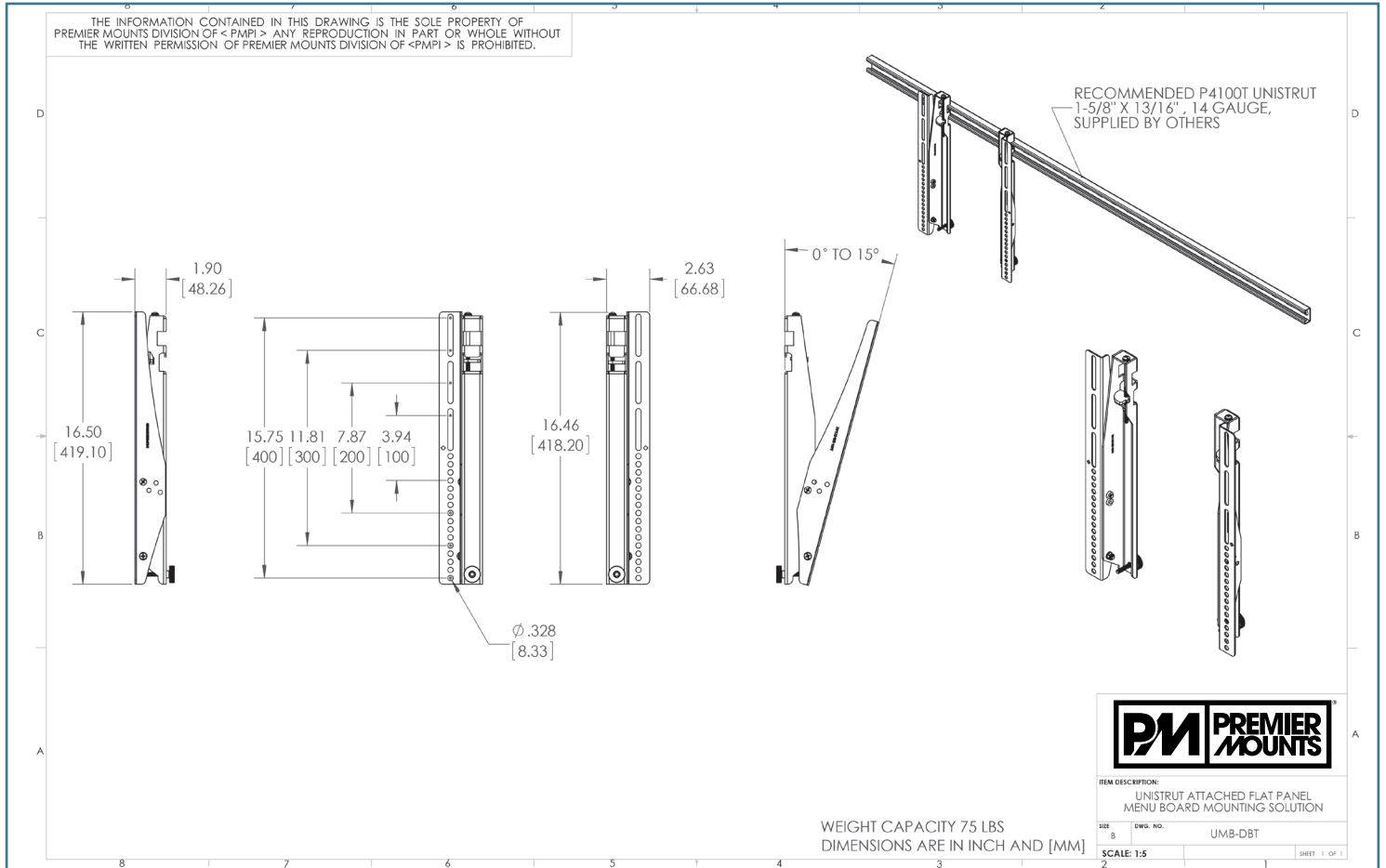

Specifications subject to change without notice