

WEIGHT CAPACITY 160 LBS

DESCRIPTION:			
IN-WALL BOX FOR AM100 AM175 & AM300			
PART NO.			
INW-AM325			
MAX. WEIGHT CAPACITY	DIMENSION ARE IN	SCALE:	SHEET
LB.	INCH AND [MM]	1:8	1 OF 1

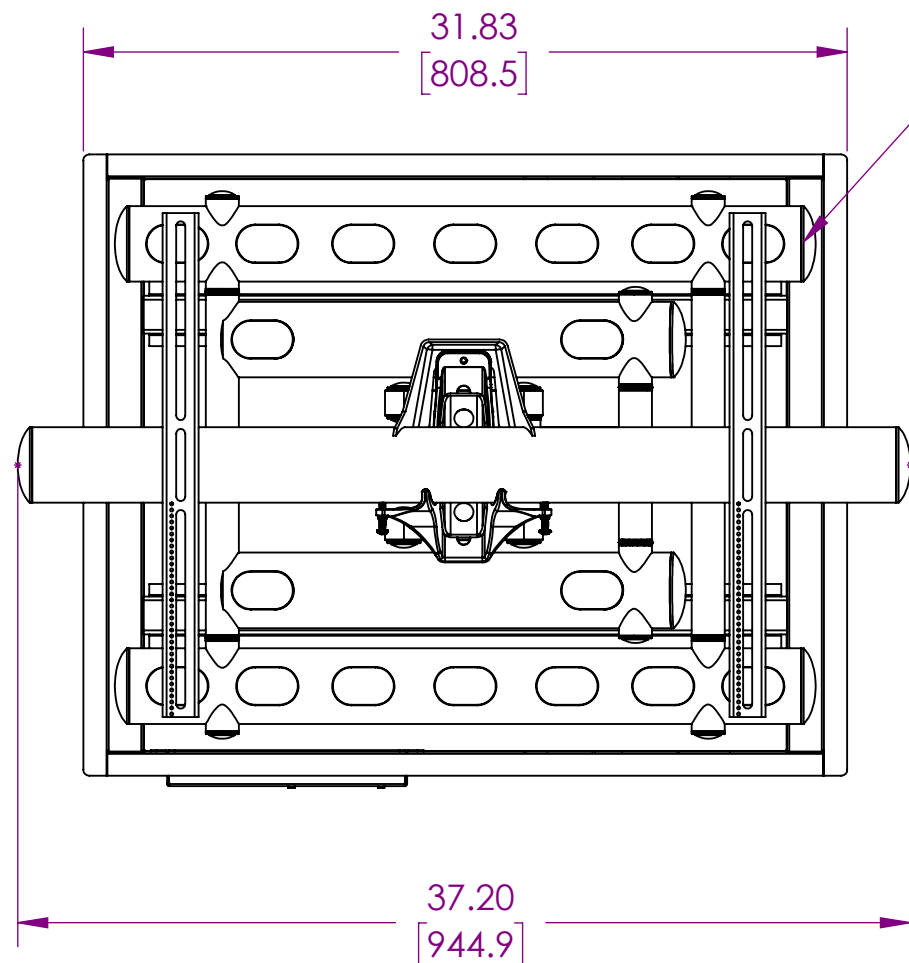

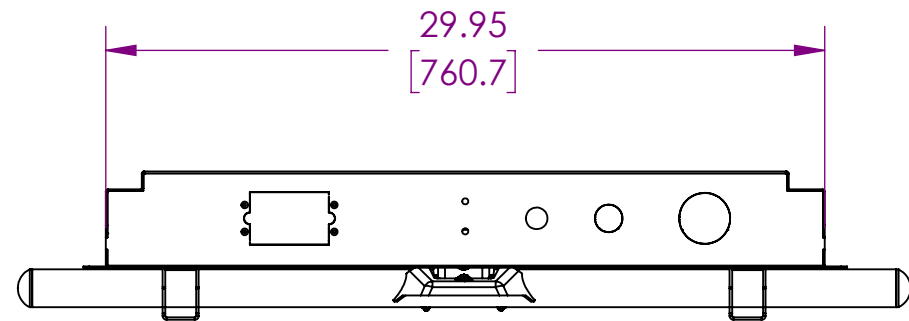

AM300 MOUNT
(SOLD SEPARATELY)

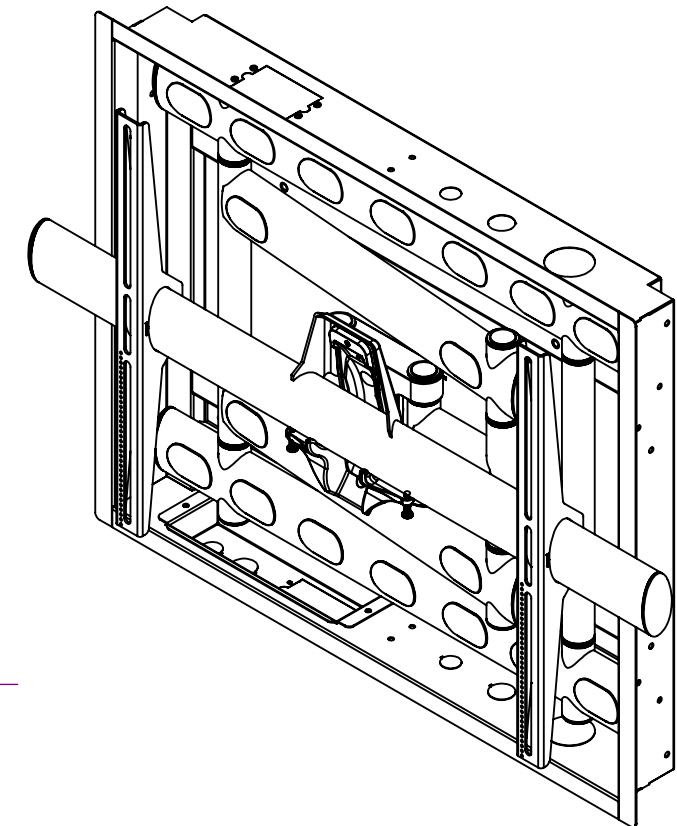
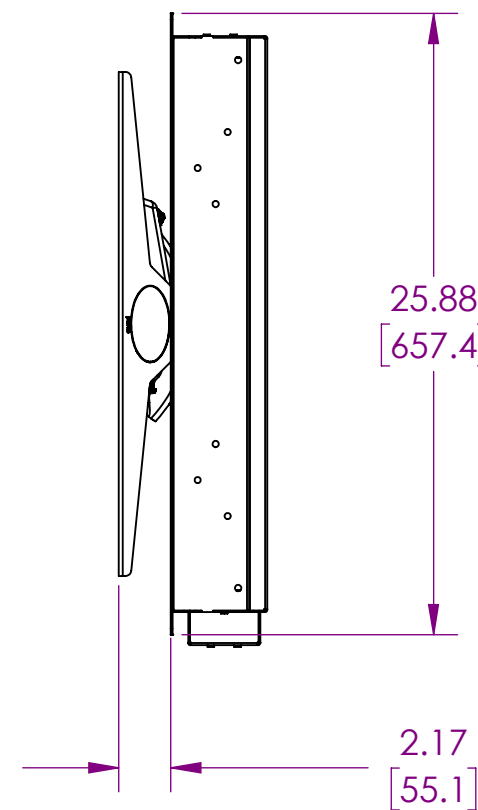

SHOWN WITH AM300

THE MAXIMUM WEIGH CAPACITY OF THE AM325 IS 160 LBS
WHEN PAIRED WITH A SPECIFIC PREMIER MOUNTS FLAT PANEL MOUNT
RESTRICT TO THE WEIGHT CAPACITY OF THE MOUNT LESS THE 160LBS
MAKE SURE NOT TO EXCEED THE MAXIMUM WEIGHT OF THE INW-AM325

DESCRIPTION: IN-WALL BOX FOR AM100 AM175 & AM300			
PART NO. INW-AM325			
MAX. WEIGHT CACITY LB.	DIMENSION ARE IN INCH AND [MM]	SCALE: 1:8	SHEET 1 OF 1



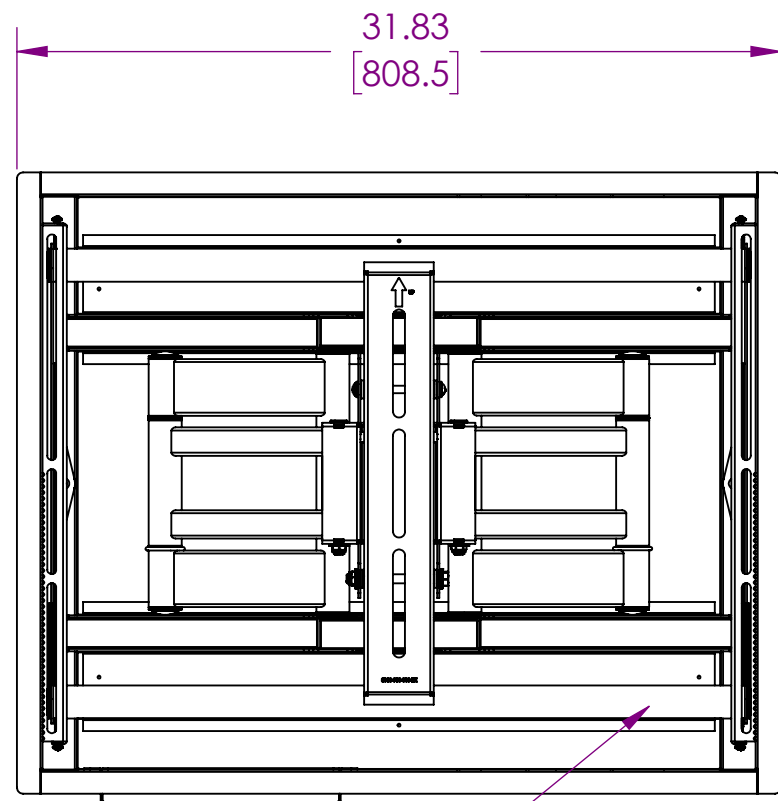
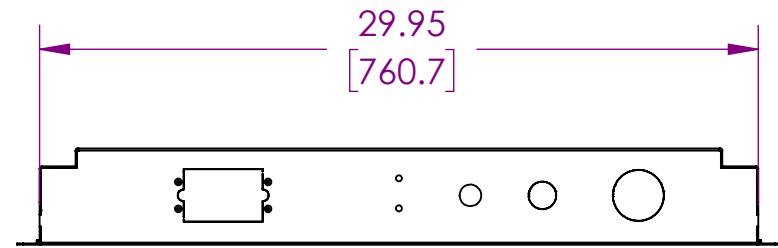

AM175
(SOLD SEPARATELY)

THE AM175 WILL
SIT FLUSH TO
THE IN-WALL BOX

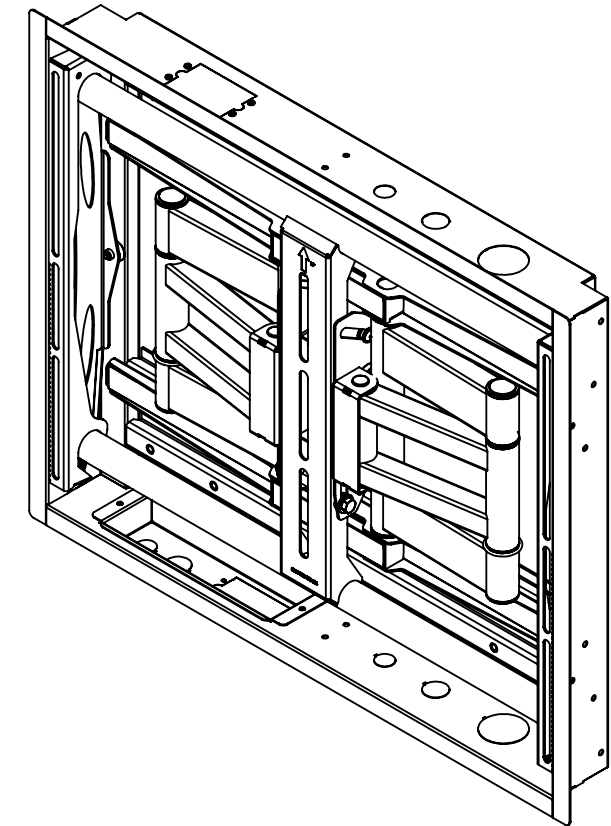
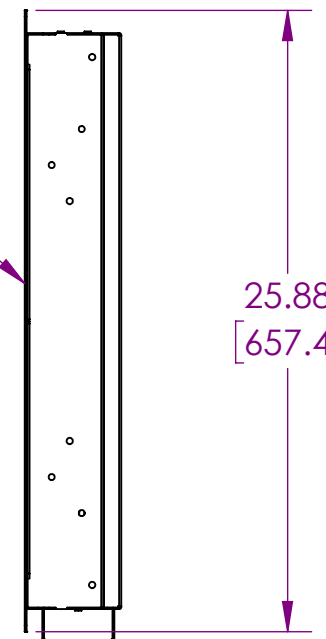

SHOWN WITH AM175

THE MAXIMUM WEIGH CAPACITY OF THE AM325 IS 160 LBS
WHEN PAIRED WITH A SPECIFIC PREMIER MOUNTS FLAT PANEL MOUNT
RESTRICT TO THE WEIGHT CAPACITY OF THE MOUNT LESS THE 160LBS
MAKE SURE NOT TO EXCEED THE MAXIMUM WEIGHT OF THE INW-AM325

DESCRIPTION: IN-WALL BOX FOR AM100 AM175 & AM300			
PART NO. INW-AM325			
MAX. WEIGHT CAPACITY LB.	DIMENSION ARE IN INCH AND [MM]	SCALE: 1:8	SHEET 1 OF 1



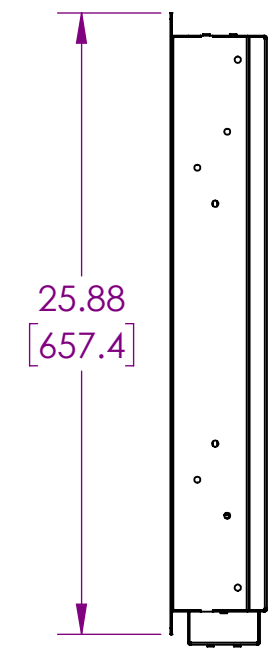
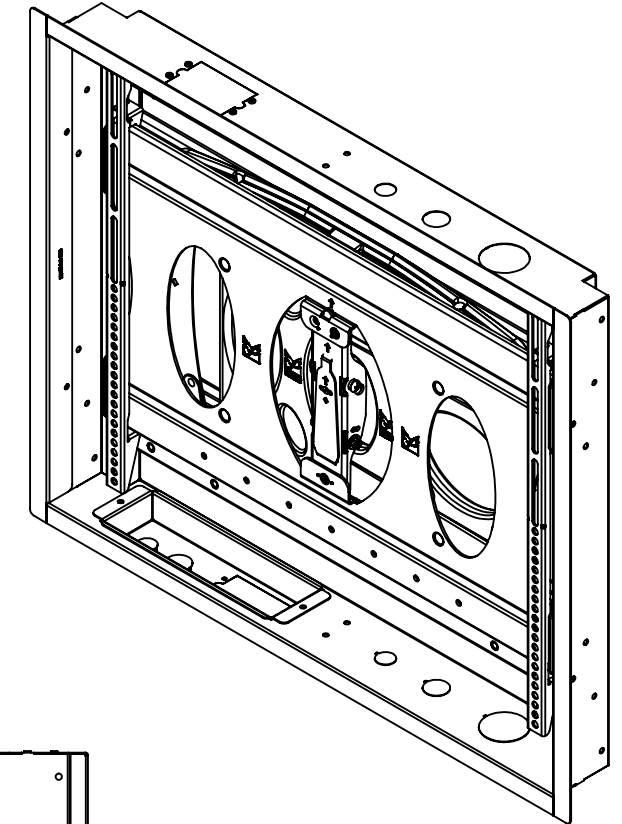
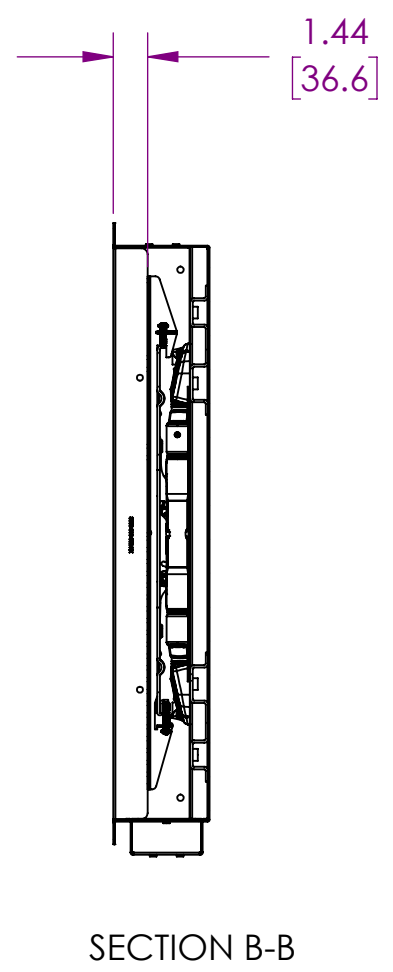
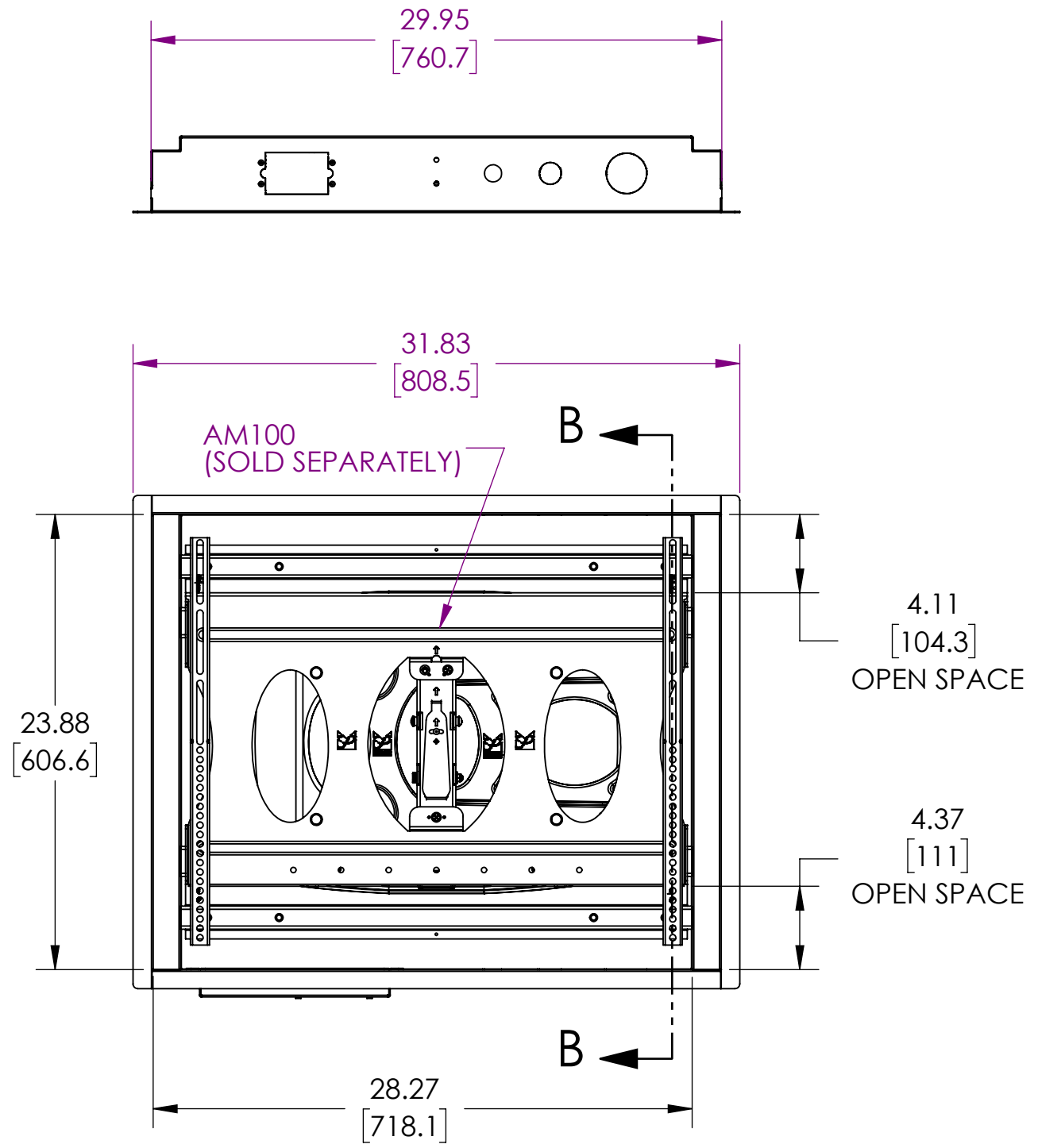

SHOWN WITH AM100

THE MAXIMUM WEIGH CAPACITY OF THE AM325 IS 160 LBS
WHEN PAIRED WITH A SPECIFIC PREMIER MOUNTS FLAT PANEL MOUNT
RESTRICT TO THE WEIGHT CAPACITY OF THE MOUNT LESS THE 160LBS
MAKE SURE NOT TO EXCEED THE MAXIMUM WEIGHT OF THE INW-AM325

DESCRIPTION: IN-WALL BOX FOR AM100 AM175 & AM300			
PART NO. INW-AM325			
MAX. WEIGHT CAPACITY LB.	DIMENSION ARE IN INCH AND [MM]	SCALE: 1:8	SHEET 1 OF 1

