



# Ultra Tilt Dual Swivel Ceiling Mounts for displays up to 75" and 200lbs.

**ITEMS:** 7170-1158-00, 7170-1158-01

**WEIGHT CAPACITY:** 200 LB / 90.7 KG.

## FEATURES

- Up to 30° of fixed tilt on each display
- 90° independent swivel on each display
- Turnkey design ensures a streamlined installation
- Mounting holes for gang boxes and media player brackets
- Compatible with Premier Mounts fixed and adjustable length ceiling pipes
- Built from high-grade steel, this mount provides secure and durable support for your displays.

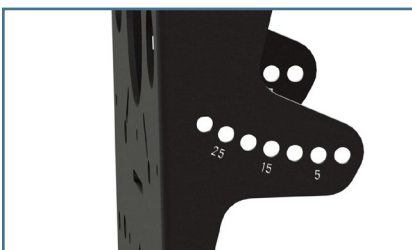

Premier Mounts' dual ultra-tilt ceiling mount is designed to elevate your digital signage experience. This innovative dual ceiling mount solution allows you to create dynamic and engaging visual displays up to 75".

This dual swivel ceiling mount features 30 degrees of tilt and 90 degrees of independent swivel for each display, providing unparalleled flexibility in positioning and orientation. These features help guarantee content is displayed clearly and effectively.

Mounting holes for gang boxes and media player brackets allow for customization and integration with your existing setup. This flexibility enables you to tailor the display mount to your specific needs and preferences, ensuring a seamless integration with your overall system.

The dual ultra-tilt ceiling mount is ideal for various settings, including digital signage, live events, transportation centers, retail, quick service restaurants, hospitality, and conference centers. Its versatility makes it a valuable tool for businesses and organizations seeking to enhance their visual communications.

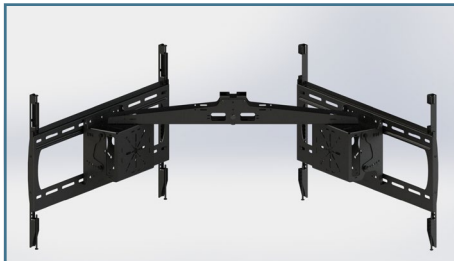

**7170-1158-00**  
Ultra Tilt Dual Swivel Ceiling Display Mount for displays up to 75" and 200lbs.

### KIT INCLUDES

- 2 - P4263F
- 2 - Ultra-Tilt Adapter
- 1 - T-BAR

**CEILING SUPPORT AND SUSPENSION ADAPTER ARE NOT INCLUDED!** Must be ordered separately.



**7170-1158-01**  
Ultra Tilt Dual Swivel Ceiling Display Mount for displays up to 75" and 200lbs. - Portrait

### KIT INCLUDES

- 2 - P4263FP
- 2 - Ultra-Tilt Adapter
- 1 - T-BAR

**CEILING SUPPORT AND SUSPENSION ADAPTER ARE NOT INCLUDED!** Must be ordered separately.



# 7170-1159-00 Ultra Tilt Dual Swivel Ceiling Display Mount for displays up to 75" and 200lbs.

## 7170-1158-00

WEIGHT RATING	TILT	SWIVEL	VESA COMPATABILITY
200lbs./Display	30°	90°	200mm x 200mm - 800mm x 500mm
KIT COMPONENTS		SPCS (W x H x D)	HARDWARE NEEDED
P4263F x2   Ultra Tilt Adapter x2   T-BAR Bracket x1		33.25" x 21.38" x 38.42"	Ceiling support adapter and 1.5" NPT pipe

### PRODUCT DIMENSIONS

THE DESIGN, DETAILS, AND THIS DOCUMENT ARE THE PROPERTY OF GAMBER-JOHNSON  
PAGE 1 of 2



<b>PART NUMBER:</b> 7170-1158-00	<b>DESCRIPTION:</b> DISPLAY MOUNT, T-BAR 32" w/ 1.5" NPT + UTAs + P4263F	<b>WEIGHT (LBS):</b> 47	<b>RATING (LBS):</b> 400
----------------------------------	--	-------------------------	--------------------------

SEE DIMENSIONAL DRAWINGS FOR EACH PART FOR MORE INFORMATION:  
- P4263F  
- 7160-1784-01

RATING (LBS): 175  
PER DISPLAY

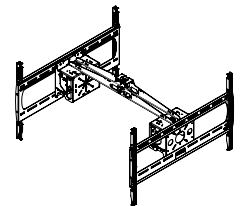
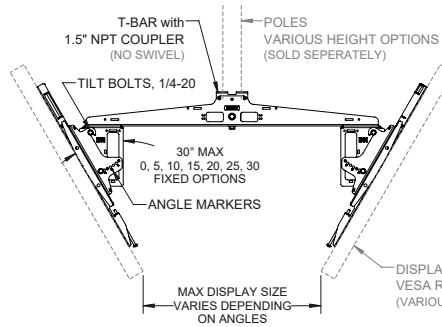
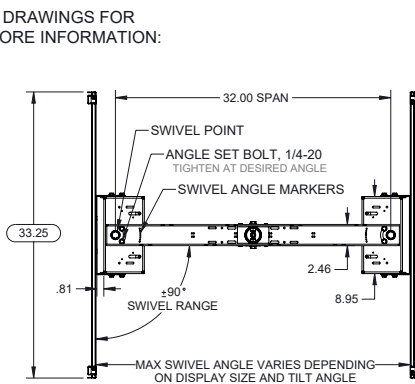

DISPLAY VESA RANGE = 815mm X 525mm (VARIOUS HARDWARE INCLUDED)

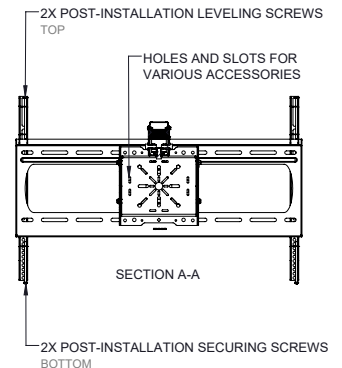
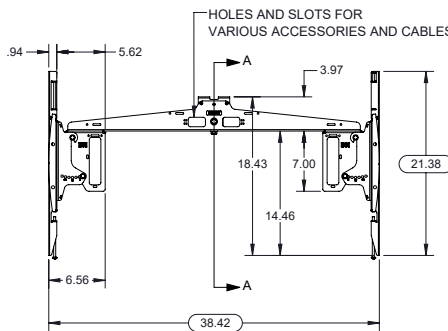
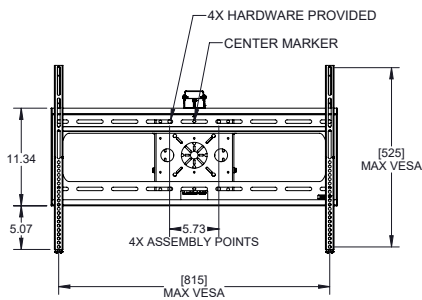



# 7170-1158-01 Ultra Tilt Dual Swivel Ceiling Display Mount for displays up to 75" and 200lbs. – Portrait

## 7170-1158-01

WEIGHT RATING	TILT	SWIVEL	VESA COMPATABILITY
200lbs./Display	30°	90°	200mm x 200mm - 500mm x 700mm

KIT COMPONENTS	SPECS (W x H x D)	HARDWARE NEEDED
P4263FP x2   Ultra Tilt Adapter x2   T-BAR Bracket x2	22.4" x 30.6" x 38.42"	Ceiling support adapter and 1.5" NPT pipe

### PRODUCT DIMENSIONS

THE DESIGN, DETAILS, AND THIS DOCUMENT ARE THE PROPERTY OF GAMBER-JOHNSON  
PAGE 2 OF 2



PART NUMBER:	DESCRIPTION:	WEIGHT (LBS):	RATING (LBS):
7170-1158-01	DISPLAY MOUNT, T-BAR 32" w/ 1.5" NPT + UTAs + P4263FP	47.3	400

SEE DIMENSIONAL DRAWINGS FOR EACH PART FOR MORE INFORMATION:

- P4263FP
- 7160-1784-01

RATING (LBS): 175  
PER DISPLAY

