

# PRODUCT DIMENSIONS

<b>PART NUMBER:</b> PSD-SHLFXL	<b>DESCRIPTION:</b> SHELF, LARGE SHELF FOR DUAL POLE BASE AND LFC CART	<b>WEIGHT (LBS):</b> 27	<b>RATING (LBS):</b> 25*
--------------------------------	--	-------------------------	--------------------------

\*RATED FOR 25 LBS AT DUAL POLE MOUNTING POSITION AND 50 LBS ON THE LFC-(L/LB) CART

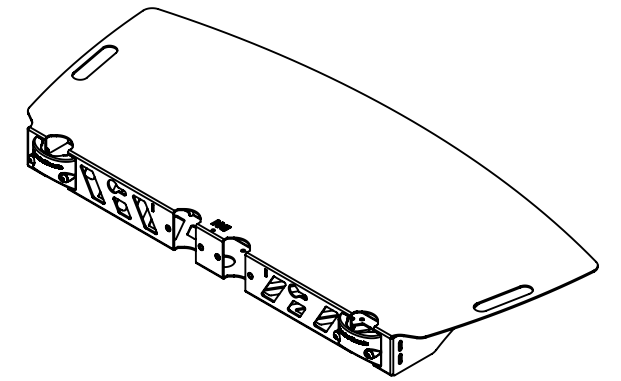
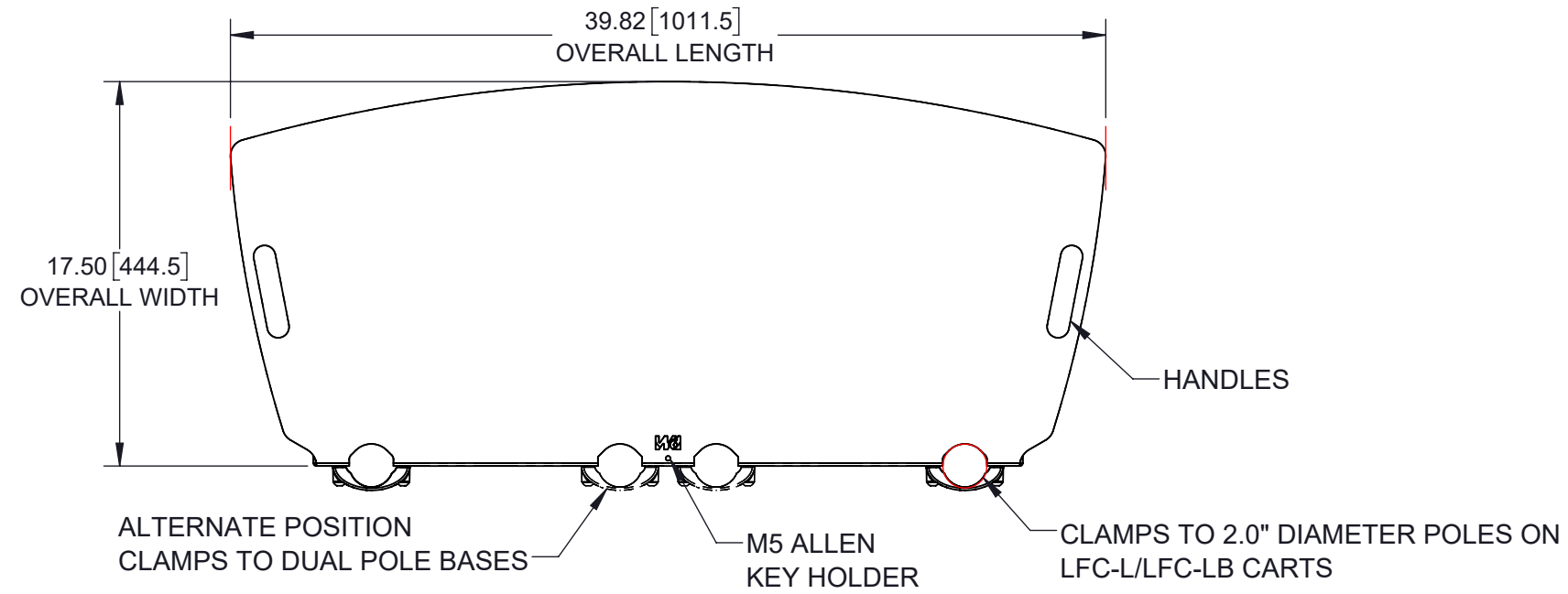

COMPARTMENT (X3):  
APPROX. 10" L X 3.25" X 2.5"

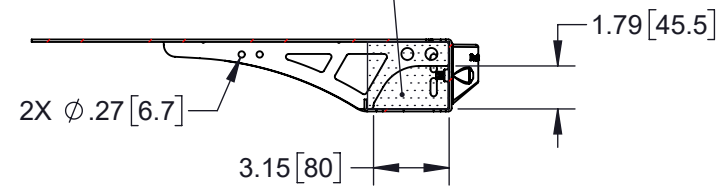

SECTION A-A

